

BOARD OF PUBLIC WORKS

AUTHORIZED BY AN ACT OF THE GENERAL ASSEMBLY MARCH 15, 1901
TO ESTABLISH, CONTROL AND REGULATE AN ELECTRIC LIGHT PLANT
WATER WORKS AND A SEWER SYSTEM FOR THE TOWN OF LEWES

107 FRANKLIN AVENUE
LEWES, DELAWARE 19958

ELECTRICAL UTILITY SPECIFICATION FOR DEVELOPERS

TABLE OF CONTENTS

000	STANDARD SPECIFICATIONS
100	SPECIFICATIONS TO DEVELOPERS
400	GROUNDING/BONDING
500	PRIMARY UNDERGROUND DISTRIBUTION
600	SECONDARY UNDERGROUND DISTRIBUTION
700	UNDERGROUND DISTRIBUTION TRANSFORMERS
800	CONDUIT/U-GUARD
1000	STREET LIGHTING DEVICES
1200	PROTECTIVE DEVICES AND SUPPORTING HARDWARE

000 – STANDARD SPECIFICATION

001 STANDARD DRAWING PROCEDURES

001 – STANDARD DRAWING PROCEDURES

1. SPECIAL INSTRUCTIONS TO DRAFTSMAN SHALL BE AS FOLLOWS:
 - DELETIONS FROM DRAWINGS SHALL BE YELLOW.
 - ADDITIONS TO DRAWINGS SHALL BE RED OR BLACK OVER YELLOW BASE.
 - INSTRUCTIONS TO CHANGE DRAWINGS SHALL BE BLUE (INK) OR BLACK (PENCIL).
2. DRAWING NUMBERS AND REVISION NUMBERS SHALL BE SHOWN IN BOTH LOCATIONS ON DRAWING USING KOH-I-NOOR ¼ INCH LETTERING GUIDE AND KOH-I-NOOR NO. 2 NIB. OR EQUIVALENT.
3. ALL HAND-LETTERING TO BE 1/8 INCH.
4. HAND-LETTERING MAY BE IN PENCIL.
5. DRAWING NOTES MAY BE HAND-LETTERED.
6. DRAWING TITLE SHALL BE LETTERED USING KOH-I-NOOR 1/8 INCH LETTERING GUIDE OR EQUIVALENT.
7. DRAFTSMAN MUST SIGN OR INITIAL AND DATE FORM IN APPROPRIATE SPACE.
8. ENGINEER MUST APPROVE DRAWING BY SIGNING OR INITIALING AND DATING IN APPROPRIATE SPACE.

100 – SPECIFICATIONS TO DEVELOPERS

- 101 STATEMENT OF STANDARDS
- 102 NOTIFICATION
- 103 GUARANTEE

101- STATEMENT OF STANDARDS

THE BOARD OF PUBLIC WORKS, CITY OF LEWES, SHALL REQUIRE THAT ALL ELECTRICAL EQUIPMENT WHICH SHALL IMMEDIATELY OR AT SOME FUTURE TIME, BE OWNED COMPLETELY OR IN PART BY THE BOARD OF PUBLIC WORKS, MEET THE REQUIREMENTS SET FORTH IN THIS SPECIFICATION.

THE REQUIREMENTS OF THIS SPECIFICATION REPRESENT THE MINIMUM ACCEPTABLE STANDARDS TO THE BOARD OF PUBLIC WORKS. ALL EXCEPTIONS TO THESE REQUIREMENTS SHALL REQUIRE WRITTEN APPROVAL BY THE BOARD OF PUBLIC WORKS PRIOR TO IMPLEMENTATION.

SPECIFICATIONS AND REQUIREMENTS SET FORTH IN THE LATEST EDITION OF THE **NATIONAL ELECTRIC CODE (NEC)** AND THE **NATIONAL ELECTRIC SAFETY CODE (NESC)** SHALL BE APPLICABLE.

EXCEPTIONS TO THE **NATIONAL ELECTRIC CODE** OR THE **NATIONAL ELECTRIC SAFETY CODE** SHALL BE CONSIDERED ONLY WHEN SUCH EXCEPTIONS ARE MORE STRINGENT AND INTENDED TO IMPROVE THE INTEGRITY OF THE ELECTRICAL SYSTEM CONTROLLED BY THE BOARD OF PUBLIC WORKS. ALL EXCEPTIONS REQUIRE WRITTEN APPROVAL BY THE BOARD OF PUBLIC WORKS PRIOR TO IMPLEMENTATION.

102 – NOTIFICATION

IT SHALL BE THE RESPONSIBILITY OF THE CONTRACTOR TO NOTIFY THE CITY OF LEWES, BOARD OF PUBLIC WORKS, FORTY-EIGHT (48) HOURS IN ADVANCE OF PERFORMING THE FOLLOWING WORK SO THAT A CITY INSPECTOR MAY BE PRESENT TO WITNESS THE WORK.

- BACKFILL CABLE TRENCHES
- ACCEPTANCE TEST OF LOW VOLTAGE CABLES
- ACCEPTANCE TEST OF HIGH VOLTAGE CABLES

103 – GUARANTEE

THE DEVELOPER SHALL GUARANTEE THE ENTIRE ELECTRICAL INSTALLATION TO BE FREE OF ALL MECHANICAL AND ELECTRIC DEFECTS FOR THE PERIOD OF ONE (1) YEAR FROM THE TIME OF FINAL ACCEPTANCE AND SUBSTANTIAL OPERATION BY THE OWNER.

THE DEVELOPER SHALL, DURING THE ONE-YEAR GUARANTEE PERIOD, ALSO BE RESPONSIBLE FOR THE PROPER ADJUSTMENT AND OPERATION OF ALL ELECTRICAL SYSTEMS AND EQUIPMENT. APPARATUS, OR DEVICES INSTALLED BY HIM/HER AND DO ALL WORK NECESSARY TO INSURE THE PROPER FUNCTIONING OF THE SYSTEMS.

400 – GROUNDING/BONDING

- 401 POLE GROUNDING
- 402 GROUND/BOND REQUIREMENTS
- 402.1 GROUNDING PRODUCTS

401 - POLE GROUNDING

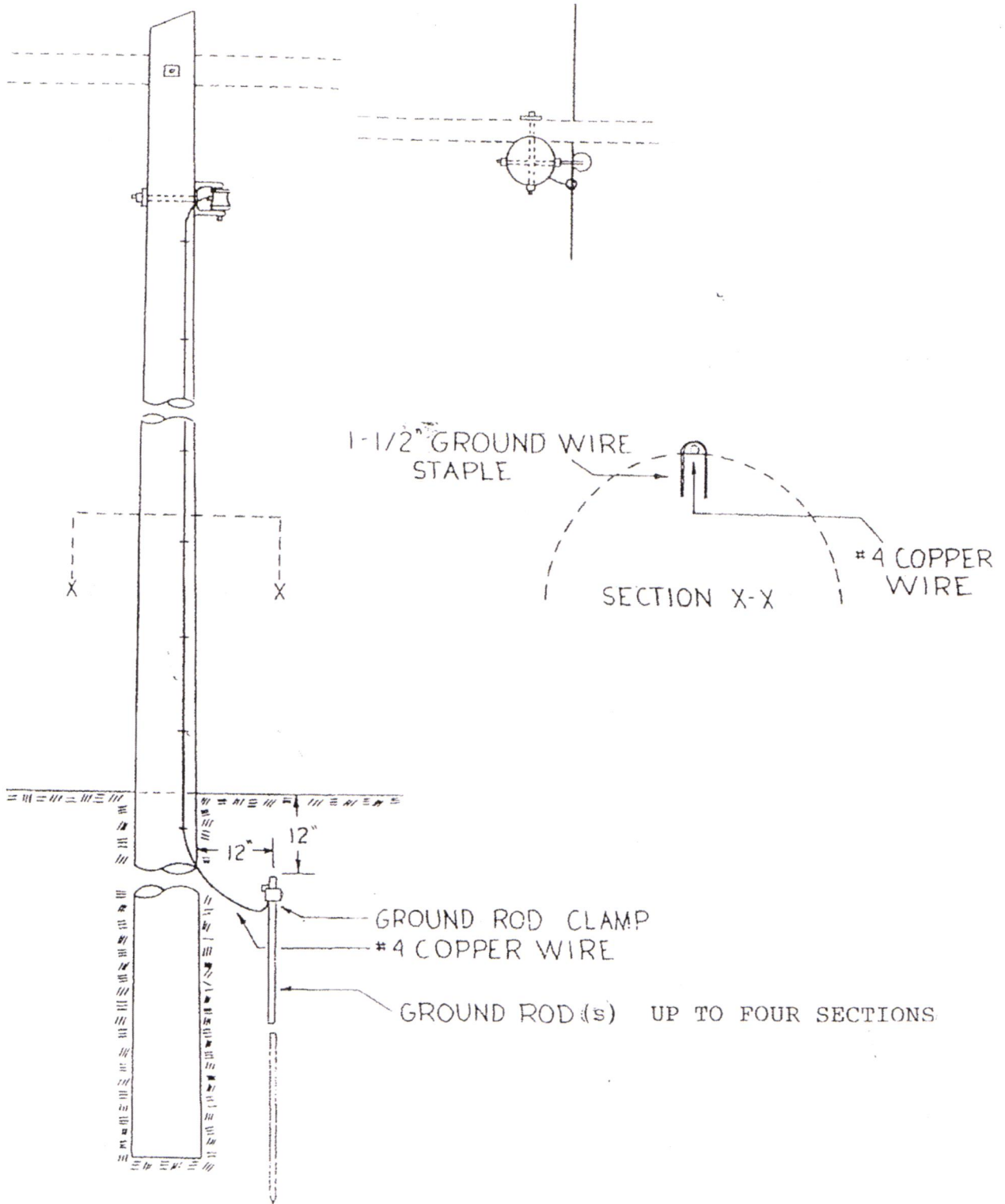

402 – GROUNDING/BONDING REQUIREMENTS

GROUND RODS SHALL BE COPPER-CLAD STEEL WITH A MINIMUM DIMENSION OF 5/8 INCH DIAMETER BY 10 FEET LONG UNLESS OTHERWISE NOTED.

ALL GROUND SHALL HAVE A RESISTANCE TO SOLID EARTH NO-TO-EXCEED 10 OHMS. ADDITIONAL GROUND ROD SECTIONS SHALL BE INSTALLED UNTIL THIS IS ACHIEVED, OR UNTIL A MAXIMUM OF FOUR (4) GROUND ROD SECTIONS HAVE BEEN INSTALLED AT A GIVEN LOCATION.

GROUND RODS SHALL BE DRIVEN FULL LENGTH IN UNDISTURBED EARTH IN ACCORDANCE WITH THE DRAWINGS. THE TOP SHALL BE AT LEAST TWELVE (12) INCHES BELOW THE SURFACE OF THE EARTH. THE GROUND WIRE SHALL BE ATTACHED SECURELY TO THE ROD AND SECURED TO THE POLE WITH APPROPRIATE GROUND CLAMPS.

ALL BARE GROUNDING CONDUCTORS SHALL NOT BE SMALLER THAN NO. 4 AWG. ALL GROUNDING CONDUCTORS SHALL BE COPPER.

ALL GROUND TERMINATIONS, SPLICES, OR CONNECTIONS SHALL BE MADE WITH COPPER DEVICES SUITABLE FOR DIRECT BURIAL IN EARTH.

MINIMUM ACCEPTABLE GROUNDING PRODUCTS ARE PRESENTED IN SECTION 402.1 OF THIS SPECIFICATION.

SECTIONAL TYPE GROUND RODS AND FITTINGS

Price Schedule 8A-1

- Sectional type ground rods have the same high quality as regular type ground rods, only threaded top and bottom. Threads are rolled after copper bonding, and both steel and copper are rolled into the thread, making it exceptionally strong.
- Threaded couplings are of high strength, corrosion-resistant alloy. Streamlined design reduces driving friction. Couplings are tapped so that they may be used on all standard threaded sectional rods.
- Driving Studs of high strength steel may be used with all standard couplings.



SECTIONAL RODS

CATALOG NUMBER	ROD SIZE (NOMINAL DIAMETER x LENGTH)		THREAD SIZE	WT. PER 100	
				(lbs.)	(kgs.)
5006S	½" x 6'	12.7mm x 1.8m	½"-13	316	143
5008S	½" x 8'	12.7mm x 2.4m	½"-13	421	191
5010S	½" x 10'	12.7mm x 3.0m	½"-13	527	239
5006LS*	½" * x 6'	12.7mm x 1.8m	⅝"-12	410	189
5008LS*	½" * x 8'	12.7mm x 2.4m	⅝"-12	546	248
5010LS*	½" * x 10'	12.7mm x 3.0m	⅝"-12	682	309
6256S*	⅝" x 6'	15.8mm x 1.8m	⅝"-11	508	230
6258S*	⅝" x 6'	15.8mm x 2.4m	⅝"-11	678	308
6260S*	⅝" x 10'	15.8mm x 3.0m	⅝"-11	847	384
7506S*	¾" x 6'	19.0mm x 1.8m	¾"-10	774	160
7508S*	¾" x 8'	19.0mm x 2.4m	¾"-10	992	450
7510S*	¾" x 10'	19.0mm x 3.0m	¾"-10	1040	562
1010S*	1" x 10'	25.4mm x 3.0m	1"-8	2248	1020

6260S



*U.L. Listed (425H). CSA lists rods ½" * and larger, 10' and longer.

COUPLINGS

CATALOG NUMBER	SIZE (NOMINAL DIAMETER)	THREAD SIZE
50C	½"	½"-13 UNS
50LC*	½" *	⅝"-12 UNS
60C*	⅝"	⅝"-11 UNS
70C*	¾"	¾"-10 UNS
80C*	1"	1"-8 UNS

60C



*U.L. Listed (425H)

DRIVING STUDS

CATALOG NUMBER	SIZE (NOMINAL DIAMETER)	THREAD SIZE
50DS	½"	½"-13
50LDS*	½" *	⅝"-12
60DS*	⅝"	⅝"-11
70DS*	¾"	¾"-10
80DS*	1"	1"-8

60DS



*U.L. Listed (425H)





GROUNDING CONNECTORS

Fargo grounding connectors are provided with standard 1/2-13 thread studs and flat surfaces for easy one wrench installation to ground distribution transformer tanks and other apparatus.

The GC-204 is machined from solid high strength hexagon bronze. The locking bolt is formed from specially drawn silicon bronze providing the optimum in corrosion resistance.

The GC-207, 208, 209 and GA-220 utilize the familiar Fargo vise type design and may be easily installed with a ratchet wrench on an unbroken ground wire eliminating any possibility of a loose ground connection due to "splicing" of the ground wire.

GC-209 is furnished with bronze jam nut on stud.

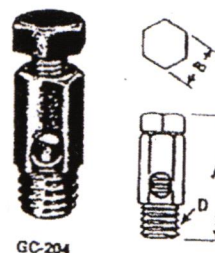

GC-204

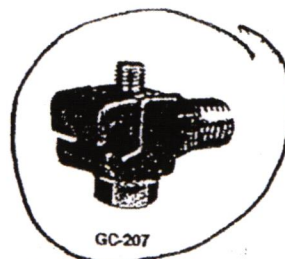

GC-207

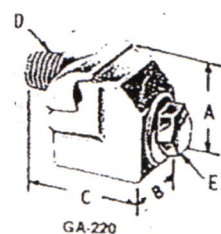
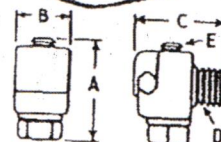

GA-220

BRONZE GROUNDING CONNECTOR						
Cat. No.	Conductor Range	Approx. Dimensions, Inches				
		A	B	C	D	E
GC-204	10 Sol. to 2 Str.	1 1/4	3/4	—	1/2	—
GC-207	6 Sol. to 1/0 Str.	1 1/4	3/4	1 1/4	1/2	3/16
GC-208	4 Str. to 2/0 Str.	1 1/4	1 1/4	1 1/4	1/2	3/16
GC-209	3 Sol. to 4/0 Str.	1 1/2	1 1/4	1 1/4	1/2	3/16

ALUMINUM GROUNDING CONNECTOR						
Cat. No.	Conductor Range	A	B	C	D	E
GA-220	6 Sol. to 1/0 Str.	1 1/4	1 1/4	2 1/4	1 1/2	3/16

GC-207

Fargo recommends bronze connectors (GC-204 through GC-209) for copper ground conductors, and aluminum connectors (GA-220) for aluminum ground conductors.

The Fargo GC-177 Connector is specifically designed for grounding flat surfaces that require a ground connection for safety purposes.

This vise type connector, fabricated from high strength electrical bronze, provides a permanent vibration proof connection. The large flat surface of the male casting provides secure mounting, while the "V" shaped conductor groove assures alignment of grounding connector.

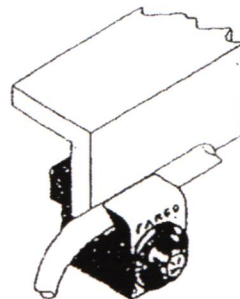

GC-177

GROUNDING CONNECTOR - Flat Surfaces to Conductor					
Cat. No.	Plate/Bar Thickness	Conductor Range	Approx. Dimensions, Inches		
			A	B	C



BURNDY
an FCI Company

GROUNDING



TYPE GX GROUND CONNECTOR FOR COPPER CABLES

High copper alloy ground connector for cross connecting a wide range of cable. The high copper alloy cast body, DURIMUM U-bolts, nuts, and lockwashers make the GX suitable for burial in soil or concrete. One wrench installation. UL467 listed. Acceptable for direct burial.

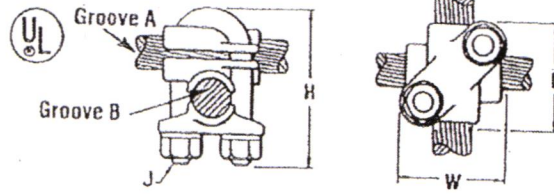

Catalog Number	Conductor		H	J	L	W
	Groove A	Groove B				
GX4C4C	8 Sol.-4 Str.	8 Sol.-4 Str.	1 7/8	3/8	1 5/8	1 5/8
GX264C	4 Sol.-2/0 Str.	8 Sol.-4 Str.	2 1/2		1 3/4	1 7/8
GX2626		4 Sol.-2/0 Str.				
GX294C	2/0 Sol.-250	8 Sol.-4 Str.	2 3/4		2 1/8	1 7/8
GX2926		4 Sol.-2/0 Str.				
GX2929		2/0 Sol.-250				
GX344C		8 Sol.-4 Str.				
GX3426	300-500	4 Sol.-2/0 Str.	4 1/4		1/2	2 5/8
GX3429		2/0 Sol.-250				
GX3434		300-500				

C-19

TYPE GRC HIGH STRENGTH GROUND ROD CLAMP FOR COPPER CABLE TO ROD

High copper alloy ground connector for joining a range of cable to rod. Slips over end of rod, one wrench installation. UL467 listed. Acceptable for direct burial.

UL REA LISTED

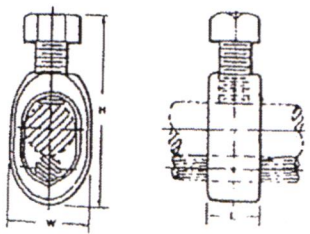

Catalog Number	Driven Rod	Conductor Range		H	W	L
		Min.	Max.			
GRC12	1/2	10 Sol.	2 Str.	2.00	.89	.63
GRC58	5/8		1 Str.	2.19	.95	.63
GRC34	3/4	8 Sol.	1/0 Str.	2.47	1.09	.65

TYPE GRD GROUNDIT GROUND ROD CLAMP FOR COPPER CABLE TO ROD

UL REA LISTED

High copper alloy ground connector for joining a wide range of cable to copper clad, galvanized steel, and stainless steel ground rods. Slips over end of rod, one wrench installation. UL listed. Acceptable for direct burial. UL467 listed.

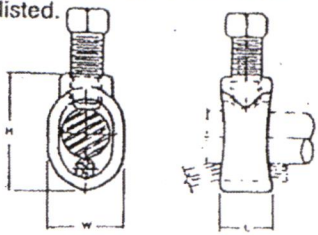
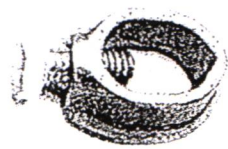

Catalog Number	Nominal Rod. Dia.	Conductor Range	H	W	L
GRD12	1/2	8 Sol. - 1/0	1.22	.79	.62
GRD58	5/8		1.35	.90	.62
GRD34	3/4		1.46	1.03	.62

500 – PRIMARY UNDERGROUND DISTRIBUTION

- 501 TRANSFORMER CONNECTIONS – RADIAL FEED
- 502 TRANSFORMER CONNECTIONS – LOOP FEED
 - 502.1 TRANSFORMER CONNECTIONS – LOOP FEED – OPEN POINT
 - 502.2 TRANSFORMER CONNECTIONS – 3 PHASE
 - 502.3 TRANSFORMER CONNECTIONS – BOX PAD FOUNDATION
- 503 15 KV, 3 PHASE, CABLE TRENCH
- 504 15 KV, 1PHASE, CABLE TRENCH WITH L.V. DISTRIBUTION
- 505 PRIMARY CABLE SPECIFICATION
 - 505.1 UNDERGROUND PRIMARY CABLE CHARACTERISTICS
 - 505.2 UNDERGROUND CABLE CHARACTERISTICS
- 506 PRIMARY CABLE ACCEPTANCE TEST
- 507 PRIMARY BUSHINGS – UNDERGROUND DISTRIBUTION TRANSFORMER
 - 507.1 PRIMARY BUSHING HARDWARE
- 508 TERMINATIONS-LINE SIDE-15 KV PRIMARY CABLE
 - 508.1 TERMINATION KITS
- 509 TERMINATIONS-LOAD SIDE-15 KV PRIMARY CABLE
 - 509.1 TERMINATIONS-ELBOW ARRESTERS AT OPEN POINTS
 - 509.2 TERMINATION HARDWARE CHARACTERISTICS
- 510 CABLE TRENCH EXCAVATION/BACKFILL
- 511 PRIMARY CABLE IDENTIFICATION
 - 511.1 PRIMARY CABLE IDENTIFICATION ILLUSTRATION
 - 511.2 CABLE LABEL SYSTEM

501. - TRANSFORMER CONNECTIONS

RADIAL FEED WITH SURGE ARRESTER

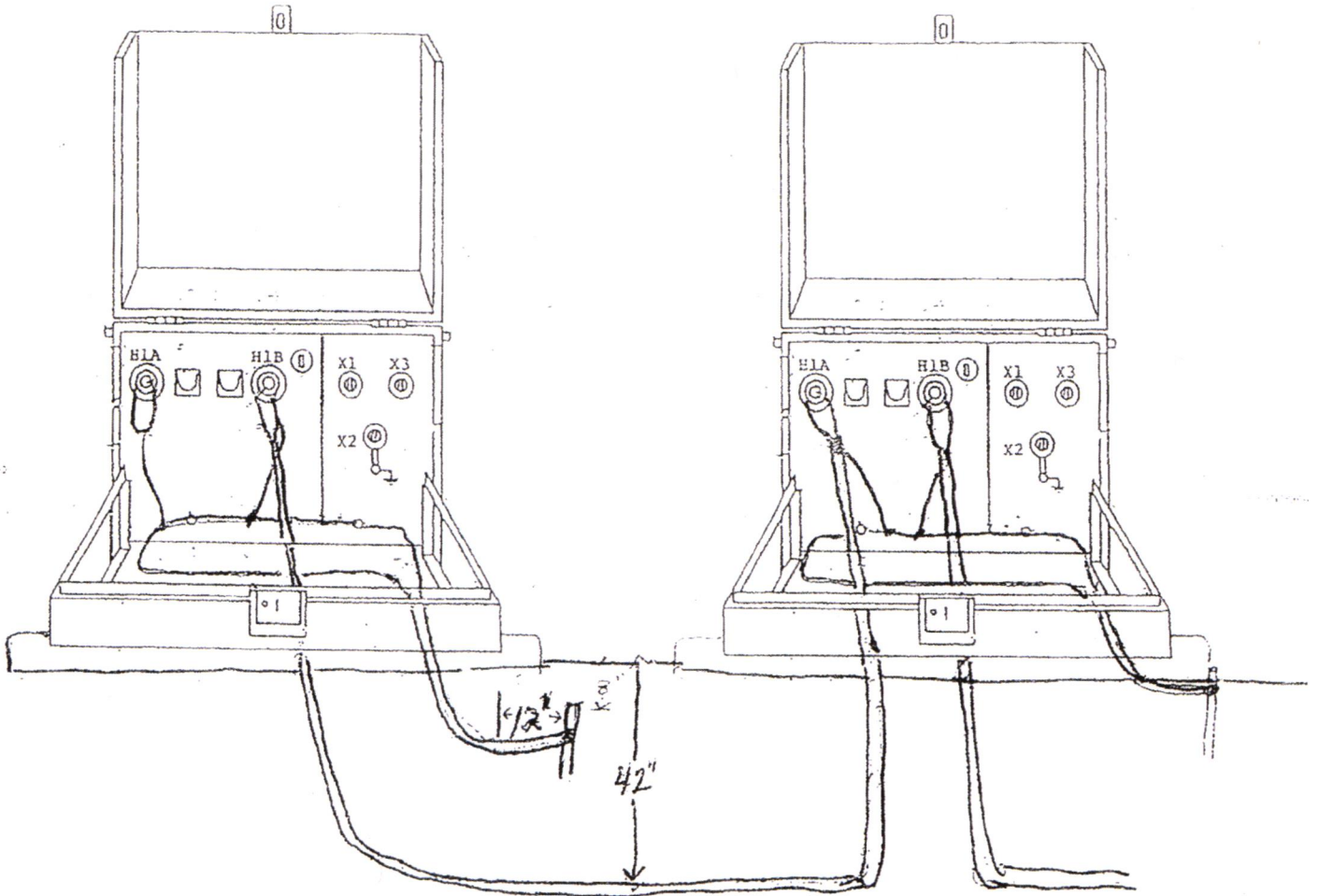

502 - TRANSFORMER CONNECTIONS LOOP FEED

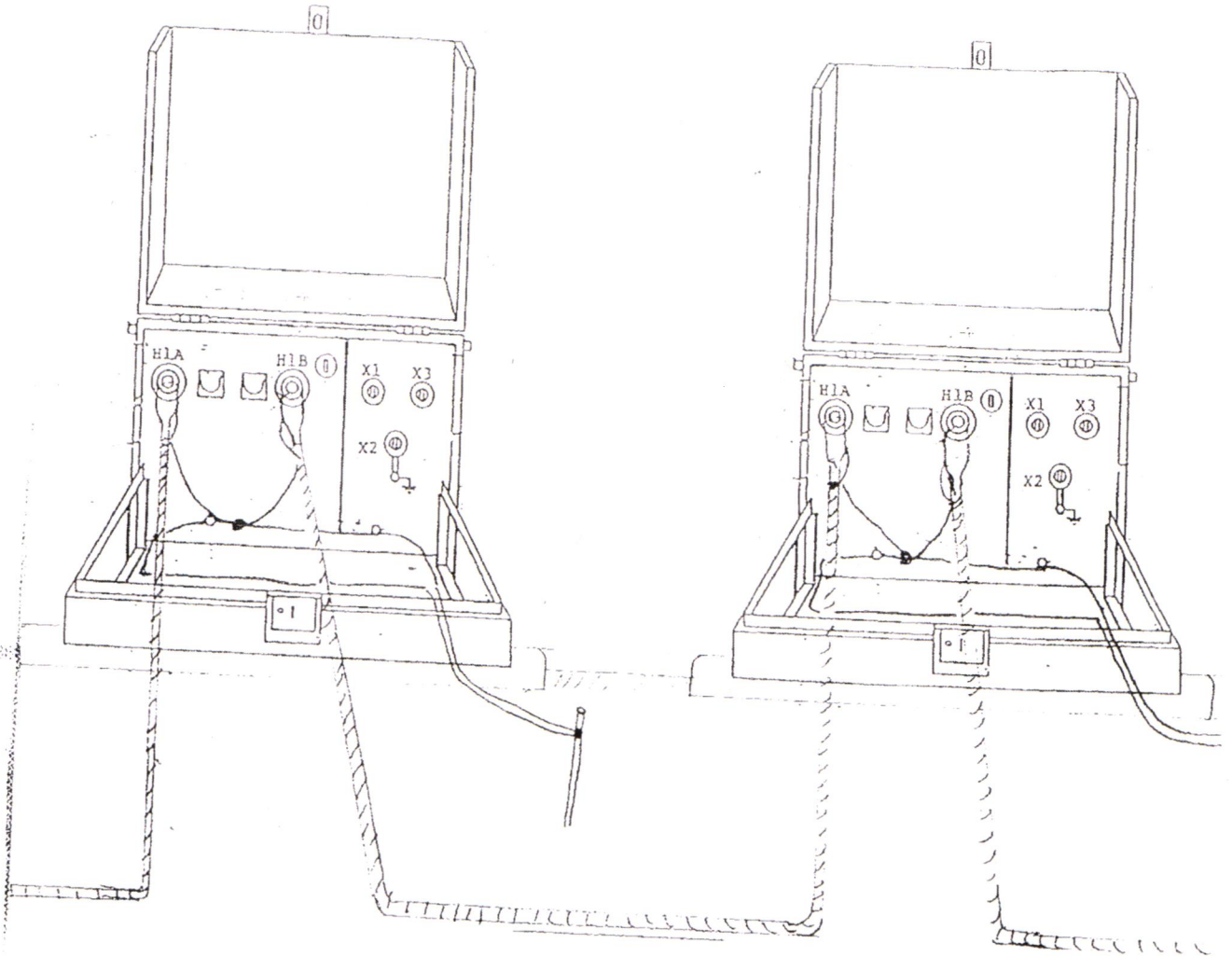

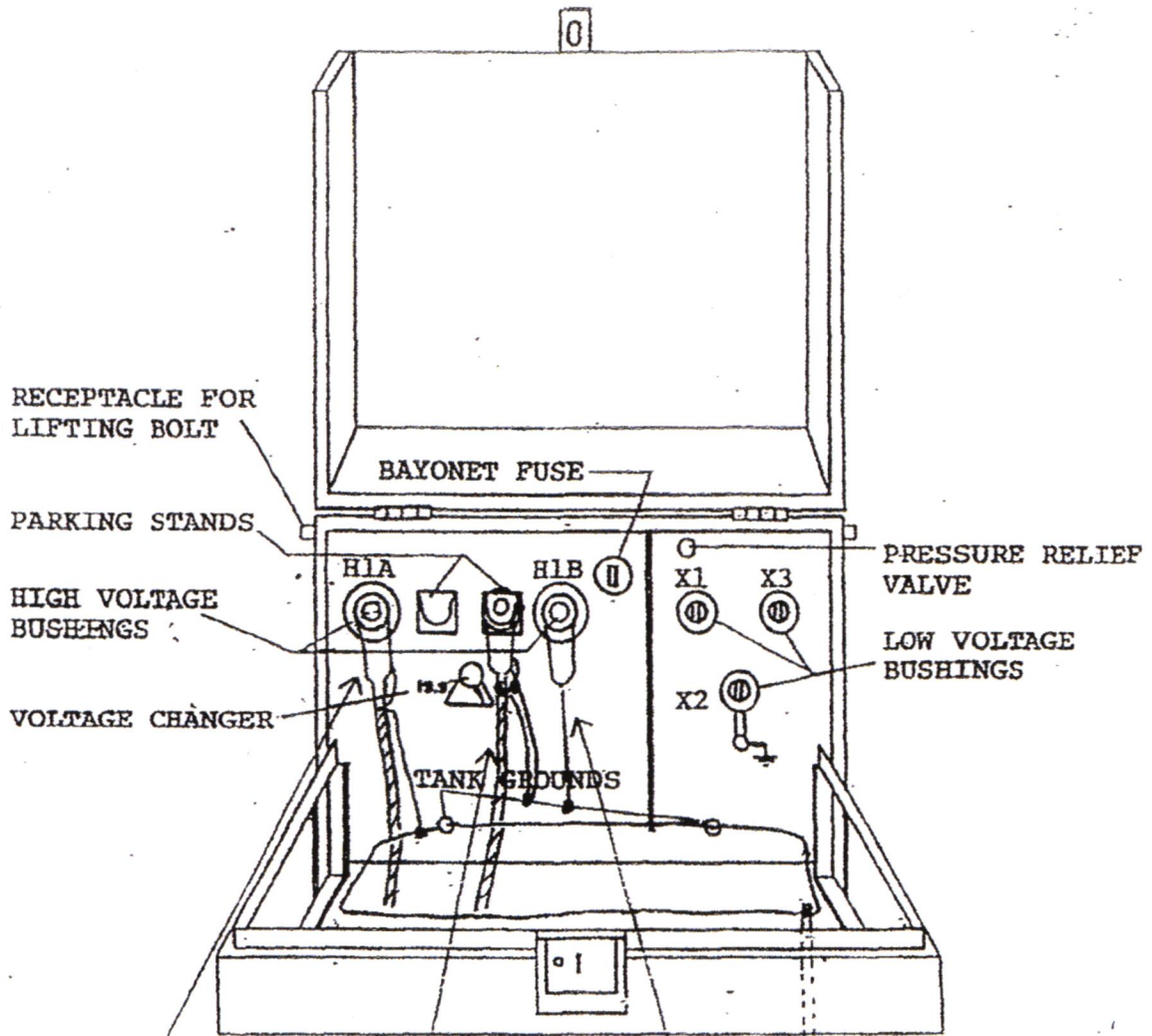

Load-Break Elbow
 Cooper# LE215B05
 Elastimold 165LR-B-5230

Parking Stand
 Arréster
 Elastimold#167PSA10VBX

Elbow Arrester
 Elastimold 167ESA-10

502.2 - TRANSFORMER CONNECTIONS

THREE PHASE

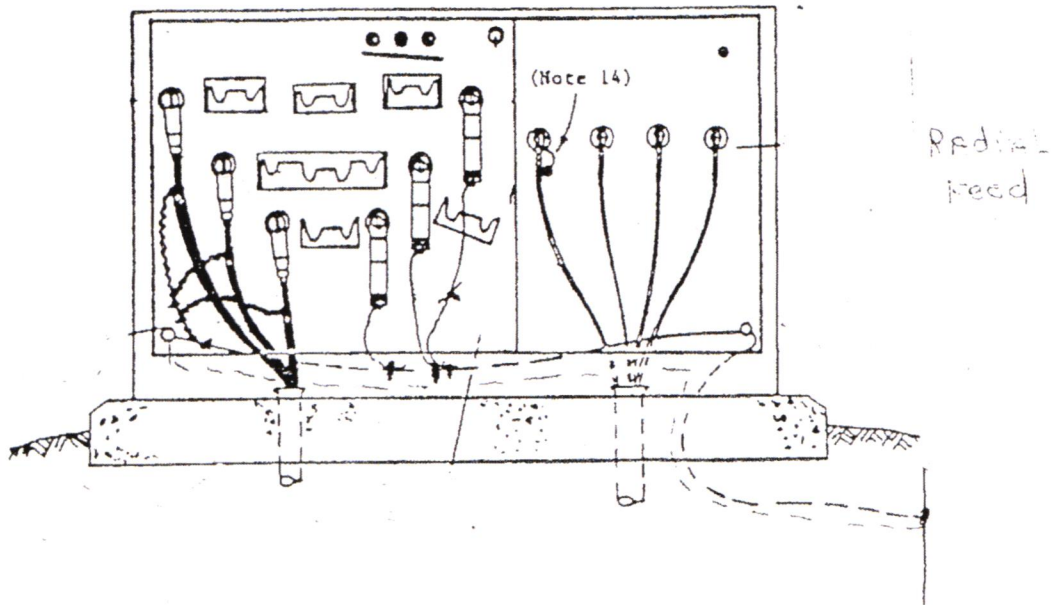
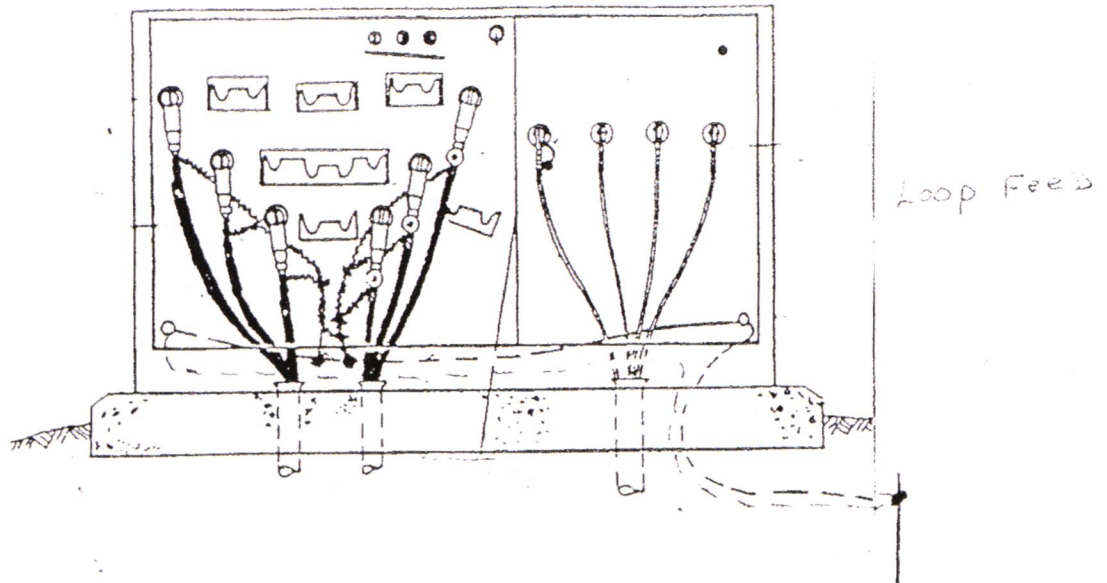

502.3 - TRANSFORMER CONNECTIONS

BOX PAD FOUNDATION

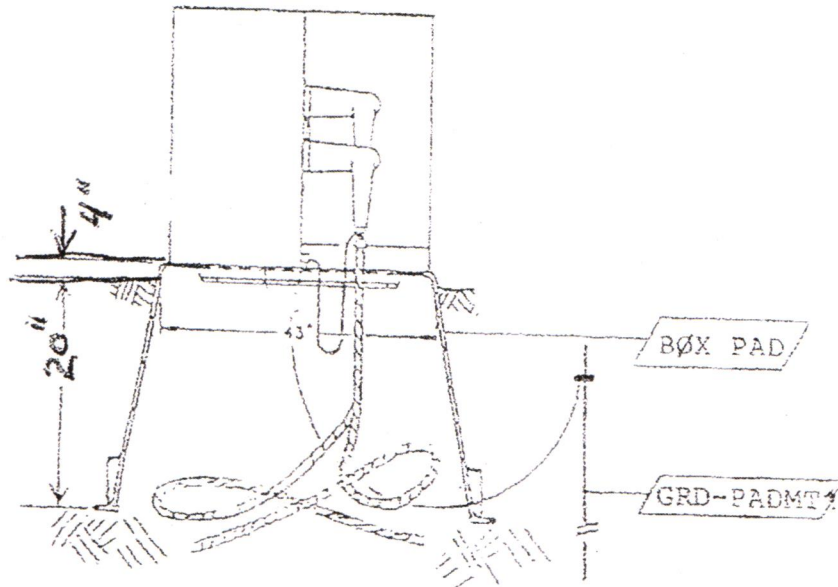
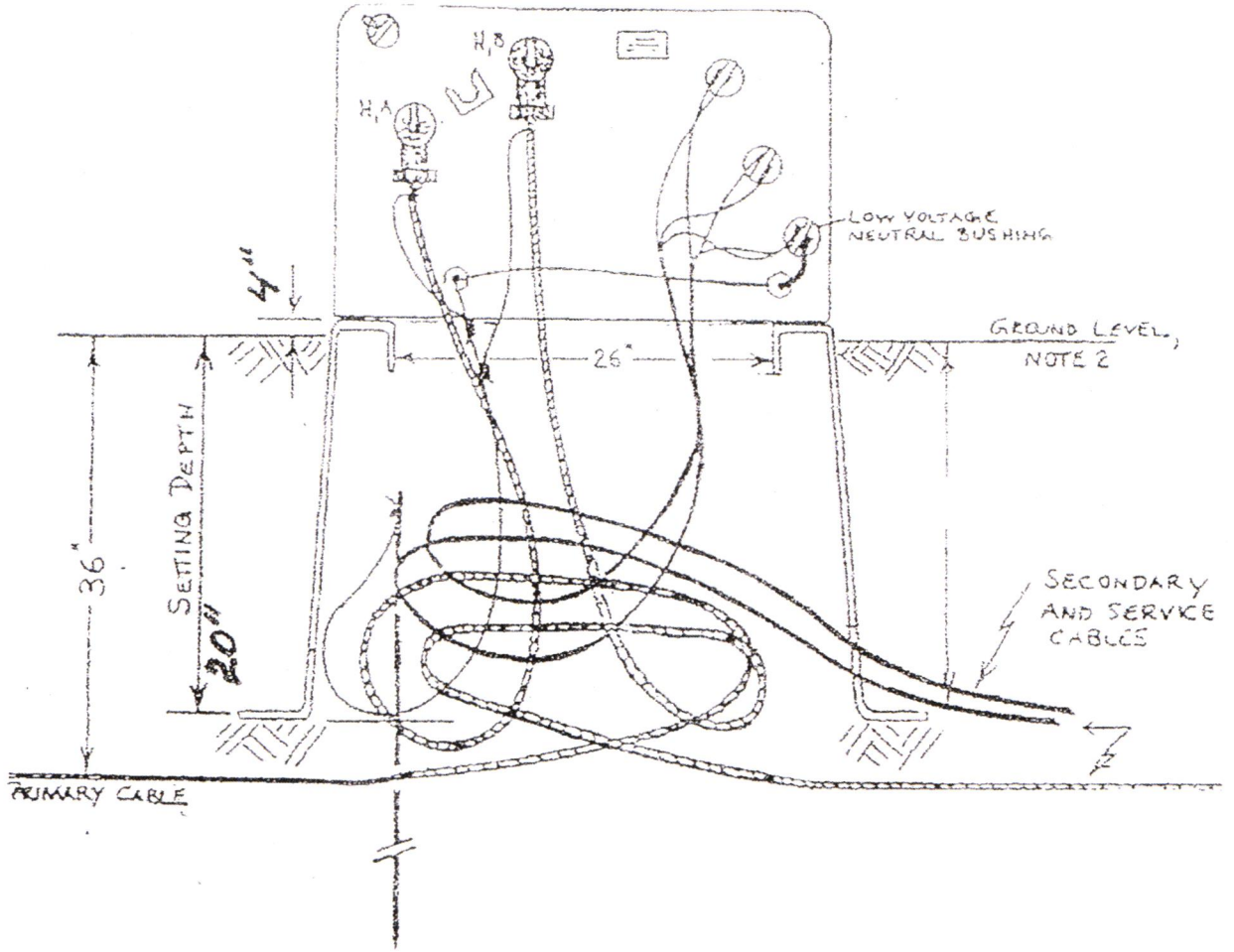

Revised 1/01

503 CABLE TRENCH SECTION 15 KV THREE PHASE
DISTRIBUTION

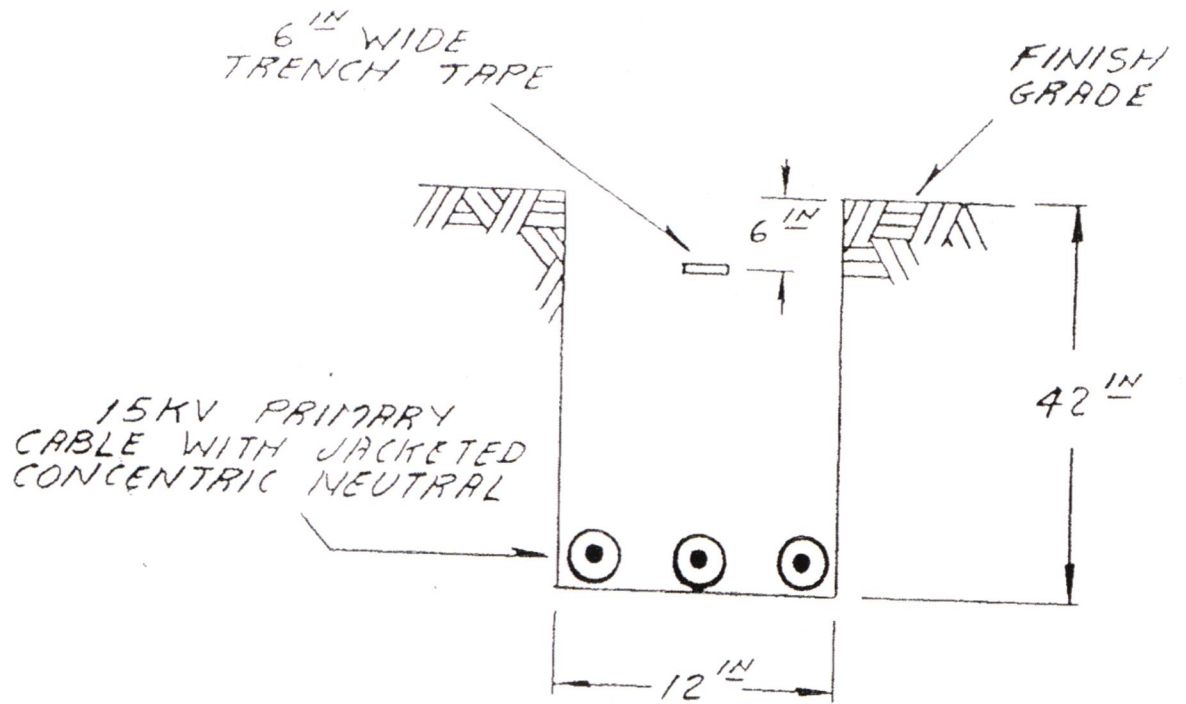

504 - 15 KV, 1Phase, Cable Trench w/ L.V. Distribution

6 IN WIDE
DETECTABLE TRENCH TAPE

FINISH
GRADE

600 VOLT DUPLEX
STREET LIGHT
CABLE IN CONDUIT

600 VOLT TRIPLEX
SECONDARY CABLE
IN CONDUIT

15 KV PRIMARY CABLE
WITH JACKETED CONCENTRIC NEUTRAL
IN CONDUIT

6 IN

24"

40"

12 IN

MEASUREMENTS
ARE FROM
FINISH GRADE
TO TOP
OF
CONDUIT

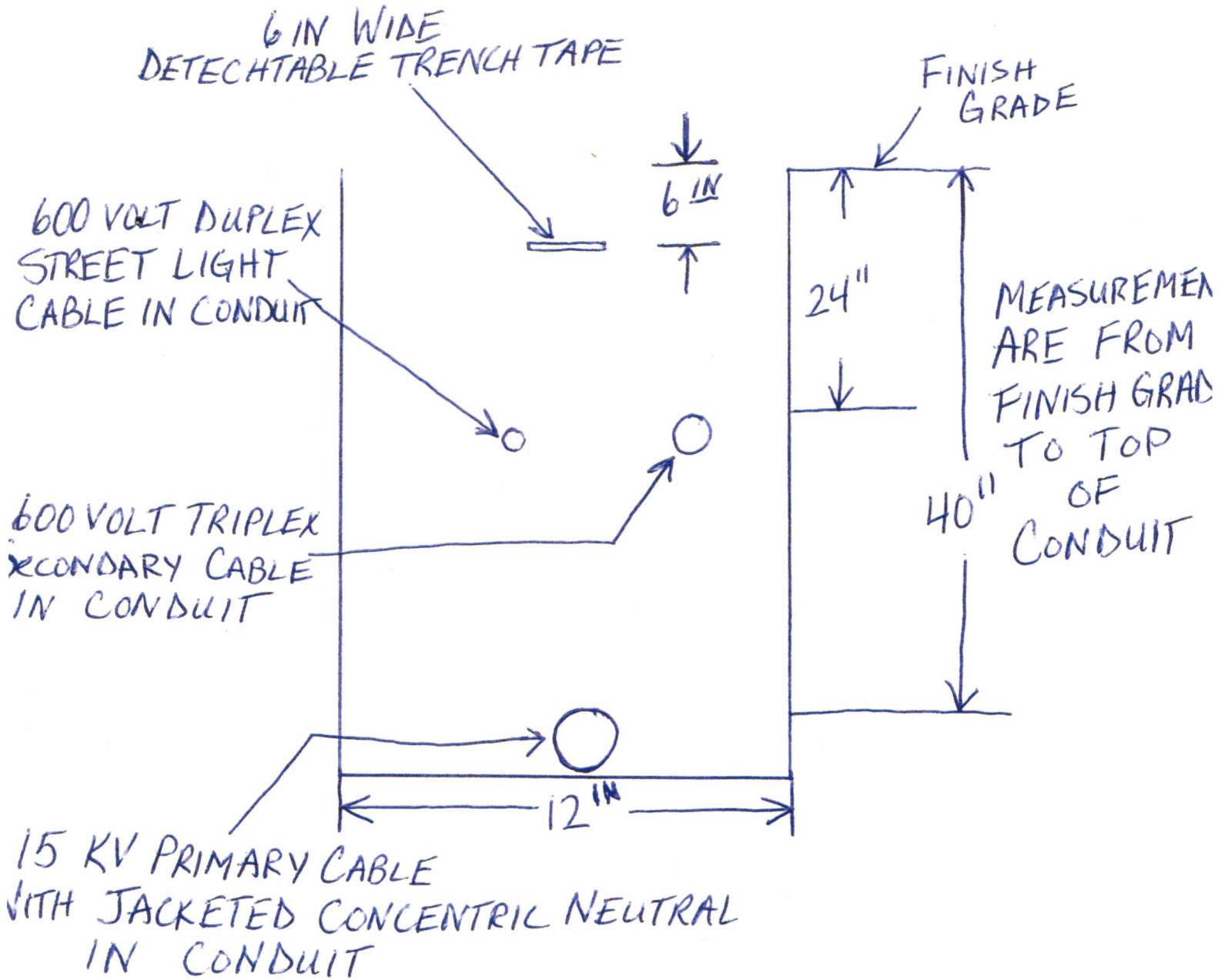

505 PRIMARY CABLE SPECIFICATION

ALL PRIMARY CABLE INTENDED FOR UNDERGROUND USE SHALL HAVE THE FOLLOWING MINIMUM ACCEPTABLE CHARACTERISTICS AND PERFORMANCE PER PRODUCT DATA SHEET 505.1 OF THIS SPECIFICATION.

Specifications

Central Conductor: Aluminum per ASTM B-609 *1/0 Solid*

Conductor Screen: Extruded semiconducting ethylene-propylene rubber meets or exceeds the requirements of ICEA S-68-516 and AEIC CS6.

Insulation: Extruded Okoguard meets or exceeds the requirements of ICEA S-68-516 for ethylene-propylene rubber and AEIC CS6.

Insulation Screen: Extruded semiconducting ethylene-propylene rubber meets or exceeds the requirements of ICEA S-68-516 and AEIC CS6.

Concentric Conductor: Bare copper wires.

Jacket: Black Okolene with red extruded stripes meets or exceeds the requirements of ICEA S-68-516 for polyethylene jackets. Complies with UL 1072 for Type MV-90 cables. CSA Listed to C68.3.

Product Features Okoguard cables meet or exceed NEMA/ICEA and REA U-1 standards. 90°C continuous operating temperature. 130°C emergency rating. 250°C short circuit rating. Excellent corona resistance. Low dielectric constant and power factor. Screens are clean stripping. Exceptional resistance to "treeing". Moisture resistant. Overall jacket provides extended life. Red extruded stripes. Excellent resistance to most chemicals. Listed as Type MV-90 for use in accordance with Article 326 of the NEC. Design Options: Yellow Stripes Additional conductor sizes Filled strand Copper central conductor Copper flat strap concentric neutral Semiconducting jacket Improved Temperature Rating.

Okoguard insulation system has been tested and qualified for operation at 105°C continuous and 140°C emergency operating temperature.

Revised 1/01

Okoguard® URO-J
15kV Underground Primary Distribution Cable-Jacketed
 Red Identification Stripes
 Aluminum Conductor/90°C Rating
 133% Insulation Levels

- A Conductor- **Solid** Aluminum
- B Strand Screen- Extruded Semiconducting EPR
- C Insulation-Okoguard
- D Insulation Screen- Extruded Semiconducting EPR
- E Concentric Conductor-Bare Copper Wires
- F Encapsulating Jacket-Okolene with 3 extruded red ID stripes



Insulation

Okoguard is Okonite's registered trade name for its exclusive ethylene-propylene rubber (EPR) based, thermosetting compound, whose optimum balance of electrical and physical properties is unequalled in other solid dielectrics. Okoguard insulation, with the distinctive red color and a totally integrated EPR system, provides the optimum balance of electrical and physical properties for long, problem free service.

The triple tandem extrusion of the screens with the insulation provides optimum electrical characteristics.

An insulation screen of ethylene-propylene rubber is extruded over the insulation. The copper concentric wires are uniformly spaced around the insulation screen. The overall polyethylene jacket provides protection against mechanical damage and corrosion.

Product identification is provided through the use of three red stripes placed 120° apart in the black jacket.

Applications

Okoguard URO-J

15kV Underground Primary Distribution Cable-Jacketed

Red Identification Stripes

Aluminum Conductor/105°C Rating

133% Insulation Levels



Okoguard Insulation: 220 mils 133% Insulation Level

Catalog Number	Conductor size (AWG or kcmil)	Nominal Dia. over Insulation (in.)	Insulation Screen Thickness (mils)	Nominal Dia. over Insulation Screen (in.)	Copper Neutral, No. x AWG (1)	Nominal O.D. (in.)	Approx. Net Weight lbs./1000'	Approx. Ship Weight lbs./1000'	90°C Ampacity Direct Burial (2)	90°C Ampacity Duct (2)	105°C Ampacity Direct Burial (2)	105°C Ampacity Duct (2)
FULL NEUTRAL												
▲ 161-23-3057	2(1X)	0.74	30	0.82	10X14	1.06	572	635	170	125	185	135
161-23-3060	2(7X)	0.77	30	0.84	10X14	1.08	590	662	170	125	185	135
161-23-3066	1(19X)	0.81	30	0.88	13X14	1.12	669	781	195	145	210	155
▲ 161-23-3069	1/0(1X)	0.80	30	0.89	16X14	1.12	721	792	220	160	235	175
▲ 161-23-9525	1/0(1X)	0.80	30	0.89	10X14*	1.12	651	718	230	170	245	185
161-23-3072	1/0(19X)	0.84	30	0.92	16X14	1.15	746	818	220	160	235	175
161-23-3075	2/0(19X)	0.89	30	0.92	14X12	1.23	900	1012	250	185	270	205
161-23-3078	3/0(19X)	0.94	30	1.01	16X12	1.28	998	1136	285	210	310	230
161-23-3081	4/0(19X)	0.98	30	1.06	14X10	1.38	1226	1357	320	240	350	260
161-23-3084	250(37X)	1.06	40	1.16	16X10	1.47	1405	1619	350	270	380	295
161-23-3090	350(37X)	1.16	40	1.26	18X.1078	1.59	1716	1912	425	310	460	340
1/3 NEUTRAL												
160-23-3057	2(1X)	0.74	30	0.82	6X14	1.06	525	621	150	120	165	135
160-23-3060	2(7X)	0.76	30	0.84	6X14	1.08	543	659	150	120	165	135
160-23-3066	1(19X)	0.81	30	0.88	6X14	1.12	586	700	175	140	185	150
→ 160-23-3069	1/0(1X)	0.80	30	0.89	6X14	1.12	604	715	195	155	215	170
160-23-3072	1/0(19X)	0.84	30	0.92	6X14	1.15	629	748	195	155	215	170
160-23-3075	2/0(19X)	0.89	30	0.96	7X14	1.20	699	826	225	180	240	195
160-23-3078	3/0(19X)	0.94	30	1.01	9X14	1.25	787	916	255	200	275	220
160-23-3081	4/0(19X)	0.99	30	1.06	11X14	1.30	884	1002	285	235	310	255
160-23-3084	250(37X)	1.06	40	1.16	13X14	1.40	1024	1168	305	250	330	275
160-23-3090	350(37X)	1.16	40	1.26	18X14	1.50	1243	1458	375	310	405	335
160-23-3093	500(37X)	1.29	40	1.39	16X12	1.72	1650	1959	450	370	490	405
160-23-3096	750(61X)	1.47	40	1.58	16X.0966	1.95	2201	2518	545	460	595	505
160-23-3099	1000(61X)	1.64	55	1.77	18X.1052	2.16	2802	3223	620	520	675	570
▲ 160-23-9590	1100(61X)	1.61	55	1.74	18X12	2.01	2470	2833	675	575	730	620

Okonite's web site, www.okonite.com contains the most up to date information.

* - Special design 64% neutral

** - Special design 1/6 neutral, compact conductor, non-CSA listed, reduced jacket thickness not in compliance with AEIC/ICEA.

(1) Individual wire size and count may vary. The resulting combination meets the 1/3 or full neutral, size requirement.

▲ Authorized stock item. Available from our Customer Service Centers.

Ampacities

(2) Full neutral, single phase ampacities are based on ICEA P-117-734 for 90°C or 105°C conductor temperature, 25°C ambient temperature, 100% load factor, and earth thermal resistivity of RHO 90.

One third neutral ampacities are based on triplexed or triangular configuration for the same conditions stated above.

506 – PRIMARY CABLE ACCEPTANCE TEST

ACCEPTANCE TESTING OF ANY CABLE SHALL BE PERFORMED WITH ALL CABLE TERMINATIONS IN PLACE BUT DISCONNECTED FROM THE SYSTEM.

CABLE TESTING SHALL BE PERFORMED BY A CERTIFIED TESTING AGENCY APPROVED BY THE CITY OF LEWES, BOARD OF PUBLIC WORKS.

CABLE RATED 600 VOLTS OR LESS SHALL NOT BE HIGH POTENTIAL TESTED; BUT SHALL BE ACCEPTANCE TESTED AT 1000 VOLTS DC FOR ONE (1) MINUTE.

PRIMARY HIGH VOLTAGE CABLES FOR 15 KV DISTRIBUTION SHALL BE ACCEPTANCE TESTED AT 40.0 KVDC FOR FIVE (5) MINUTES.

THE TEST VOLTAGE SHALL BE APPLIED IN FOUR (4) STEPS OF 10.0 KVDC AND HELD FOR FIVE (5) MINUTES AT EACH STEP UNTIL THE MAXIMUM TEST VALUE OF 40.0 KVDC IS REACHED.

A LEAKAGE CURRENT READING SHALL BE RECORDED AT THE END OF EACH FIVE (5) MINUTE STEP.

THE 40.0 KVDC TEST VOLTAGE SHALL BE MAINTAINED FOR FIVE (5) MINUTES AND A LEAKAGE CURRENT READING SHALL BE RECORDED AT ONE (1) MINUTE INTERVALS THROUGHOUT THE FIVE (5) MINUTE TEST AT 40.0 KVDC.

WARNING

THE APPLICATION OF SERVICE VOLTGE OR TEST VOLTAGE TO A CABLE MAY CAUSE A VOLTAGE RECOVERY OF SUFFICIENT MAGNITUDE TO CREATE A HAZARD. EXTREME CARE MUST BE TAKEN, TO PROPERLY AND COMPLETELY DISCHARGE THE CABLE AFTER COMPLETION OF TESTING.

507 – PRIMARY BUSHINGS

UNDERGROUND DISTRIBUTION TRANSFORMER

PRIMARY BUSHING INSERT:

- LOAD BREAK PRIMARY BUSHING INSERT SHALL BE PROVIDED TO MATCH UNIVERSAL BUSHING WELL ON TRANSFORMERS.
- BUSHING INSERT SHALL BE 15 KV, 200 AMPERE CONSTRUCTION
- THE MINIMUM ACCEPTABLE PRIMARY BUSHING INSERT SHALL BE ELASTIMOLD, CATALOG NO. 1601A3R., PER SECTION 507.1.

PRIMARY INSULATED STAND-OFF PLUG:

- PRIMARY INSULATED STAND-OFF PLUG SHALL BE PROVIDED IN THE PARKING STANDS OF EACH TRANSFORMER AT AN OPEN POINT, FOR PERMANENT PARKING OF ENERGIZED LOAD BREAK ELBOWS.
- INSULATED STAND-OFF PLUGS SHALL HAVE A SCREW CLAMP ADJUSTMENT FOR RIGID MOUNTING IN THE TRANSFORMER PARKING STAND.
- THE MINIMUM ACCEPTABLE INSULATED STAND-OFF PLUGS SHALL BE ELASTIMOLD, CATALOG NO. 160S0P, PER SECTION 507.1

PRIMARY BUSHING INSULATING CAP:

- ALL UNOCCUPIED PRIMARY BUSHINGS SHALL BE PROTECTED WITH INSULATED BUSHING CAPS.
- BUSHING INSULATING CAPS SHALL BE OF 15 KV, 200 AMPERE CONSTRUCTION.
- BUSHING INSULATING CAP SHALL BE PROVIDED WITH A BRAIDED LEAD FOR GROUNDING OF THE CAP TO PREVENT LOW ENERGY DISCHARGE.
- BUSHING INSULATING CAP SHALL BE PROVIDED WITH HOT-STICK OPERATING EYE.
- THE MINIMUM ACCEPTABLE BUSHING INSULATING CAP SHALL BE ELASTIMOLD, CATALOG NO. 160/DRG, PER SECTION 507.1.

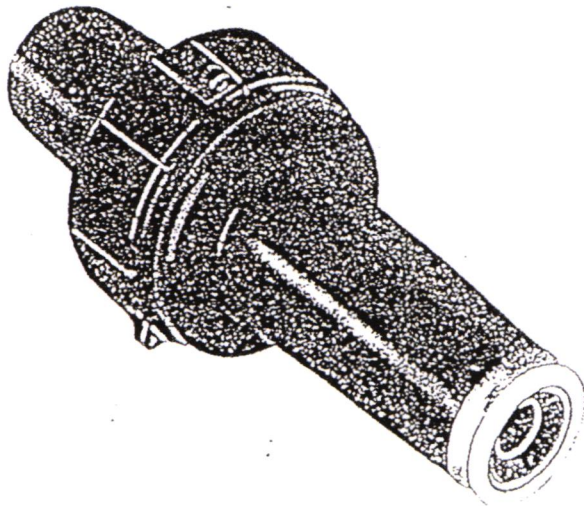

→ 1601A3R Loadbreak Bushing Insert

APPLICATION

The ELASTIMOLD 1601A3R loadbreak bushing insert, when mated with the appropriate ELASTIMOLD products, is a fully-shielded, fully-submersible, separable insulated connector designed for energized operation. The 1601A3R is suitable for use on 15-kv class, 4-wire multi-grounded systems or 3-wire, ungrounded systems. It is rated for 200-ampere loadmake/break operation at 8.3 kv phase-to-ground and 14.4 kv phase-to-phase. It may be used as the bushing interface for connecting shielded cable to the following:

- Sub-surface transformers
- Pad-mounted transformers
- Regulators • Switchgear
- Generators • Reclosers

The insulation system of the 1601A3R meets the full requirements of ANSI/IEEE standard 386-1977 for 8.3/14.4 kv load-break connectors.

Designed for use as an apparatus bushing interface, the 1601A3R is easily installed in an ELASTIMOLD universal bushing well and mated with an appropriate Elastimold product. The apparatus should be supplied with ELASTIMOLD universal bushing wells (Section 510).

INSTALLATION

Installation does not require the use of special tools or the taping of any part of the product. The 1601A3R is threaded onto the male stud of a universal bushing well and is tightened by hand. The appropriate Elastimold mating product is installed on the bushing interface completing the process.

ELECTRICAL RATINGS*

Voltage—

This product is designed for use on:

- a. Three-phase systems, either 3-wire or 4-wire, ungrounded or grounded, which have a maximum phase-to-ground voltage of 8.3 kv and which are nominally designated 15-kv class.
- b. Single-phase laterals of three-phase systems described above.
- c. Systems not exceeding 14.4 kv across the contacts during the switching operation (loadmake, loadbreak, or fault close).

BIL: 95 kv, 1.2 x 50-microsecond wave

Withstand:

35 kv, 60 Hz, 1 minute

55 kv, dc, 15 minutes

Corona voltage level: 11 kv

Current—

Continuous operation: 200 amps, rms

Short-time: 10,000 amps, rms, sym, 0.2 sec 1.3 max asym factor

Switching Operation**—

At 8.3 kv—10 loadmake, 10 loadbreak at 200 amps max, 70 to 100% lagging PF
or

At 14.4 kv—10 loadmake, 10 loadbreak at 200 amps max, 70 to 100% lagging PF

Fault Close—

After designated loadmake-loadbreak operations, 1 fault-close operation

At 8.3 kv—10,000 amps, rms, sym, 12 cycles (0.2 sec) 1.3 max asym factor
or

At 14.4 kv—10,000 amps, rms, asym, 12 cycles (0.2 sec) 1.3 max asym factor

Production Tests—

Applied potential: ac withstand—35 kv, 60 Hz, 1 minute
or

BIL—95 kv, 1.2 x 50-microsecond wave

Corona voltage level: 11 kv

*Ratings are based on United States standards. For compliance with international standards, contact the nearest Elastimold office.



ELASTIMOLD
DIVISION

AMERACE CORPORATION, ESNA PARK
HACKETTSTOWN, NEW JERSEY, U.S.A. 07840, (201) 852-1122

APPLICATION—The ELASTIMOLD 160SOP stand off plug, when used with the proper ELASTIMOLD mating products, is a fully shielded, fully-submersible, separable insulated connector designed for energized operation. It is suitable for use with 15-kv class loadbreak connectors on systems specified in the electrical ratings for this product. The 160SOP is used to isolate and "dead-end" an ELASTIMOLD elbow connector.

The 160SOP is designed to mate with the following ELASTIMOLD products

- 165LRR elbow connector
- 166LRR elbow connector
- 160DR dead-end receptacle
- 160DRG dead-end receptacle with ground lead

INSTALLATION—Installation does not require the use of special tools or the taping of any part of the product. A hot-stick tool is used to insert the 160SOP into the parking stand which must be provided on the apparatus. The ELASTIMOLD elbow connector is removed from the apparatus bushing and placed on the 160SOP to complete the process.

ORDERING INSTRUCTIONS

- The 160SOP stand-off plug kit contains the following
- 1—Stand-off plug complete with mounting hardware
 - 1—Tube, lubricant
 - 1—Wiping cloth
 - 1—Installation instruction.

To order, specify a 160SOP.

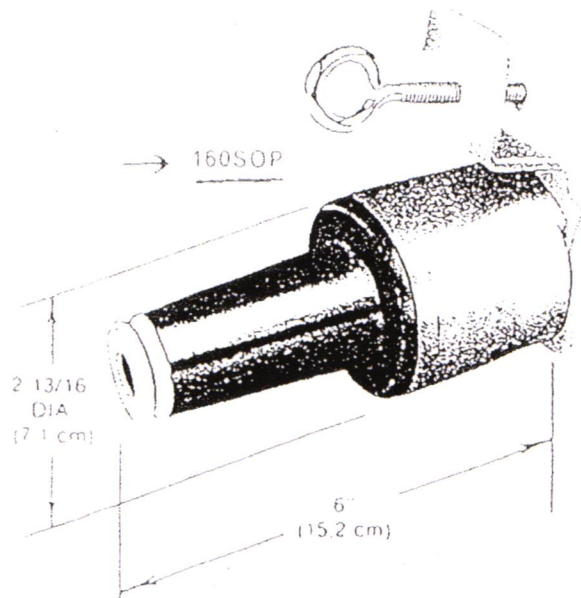

160DR Dead-End Receptacle and 160DRG Dead-End Receptacle with Ground

APPLICATION—ELASTIMOLD dead-end receptacles are fully-shielded, fully-submersible, hot-stick operable, separable insulated connectors designed for energized operation. They are suitable for use with 15-kv class loadbreak connectors on systems specified in the electrical ratings for this product. The 160DRG has an integral ground lead as part of the assembly. The 160DR and 160DRG are used to "dead-end" the following ELASTIMOLD mating products

- 1601A3R bushing insert
- 163 series junctions
- 163FTR feed-thru, 160SOP stand-off plug

INSTALLATION—Installation does not require the use of special tools or the taping of any part of the product. The 160DR or 160DRG is mated to the appropriate Elastimold product desired to be "dead-ended".

ORDERING INSTRUCTIONS

The 160DR or 160DRG dead end receptacle kit contains the following

- 1—Dead-end receptacle, 1—Tube, lubricant
- 1—Wiping cloth, 1—Installation instruction

To order, specify a 160DR or 160DRG, as required

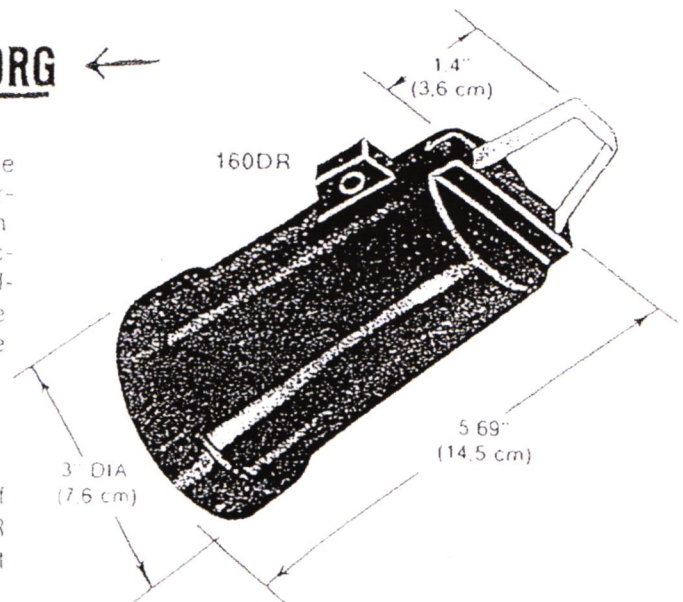

ELECTRICAL RATINGS* (For 160SOP, 160DR, 160DRG)

Voltage—

- This product is designed for use on
 - a. Three phase systems, either 3 wire or 4 wire, ungrounded or grounded, which have a maximum phase to ground voltage of 8.3 kv and which are nominally designated 15-kv class.
 - b. Single phase circuits of three phase systems described above.

BIL 95 kv, 1.2 x 50 microsecond wave

Withstand

- 35 kv, 60 Hz, 1 minute
- 55 kv, dc, 15 minutes
- Corona voltage level: 11 kv

Production Tests—

- Applied potential: ac withstand: 35 kv, 60 Hz, 1 minute
- or
- BIL: 95 kv, 1.2 x 50 microsecond wave
- Corona voltage level: 11 kv

508 – TERMINATIONS LINE SIDE

15 KV PRIMARY CABLE

15 KV PRIMARY CABLE SHALL BE TERMINATED AT THE LOAD SIDE OF POLE MOUNTED FUSED CUTOUTS WITH PREFABRICATED TERMINATION KITS.

TERMINATORS SHALL BE 3M QT-III SILICONE RUBBER TERMINATION KIT NO. 7652-S-4-2 AS PRESENTED IN SECTION 508.1 OF THIS SPECIFICATION. NO EXCEPTIONS.

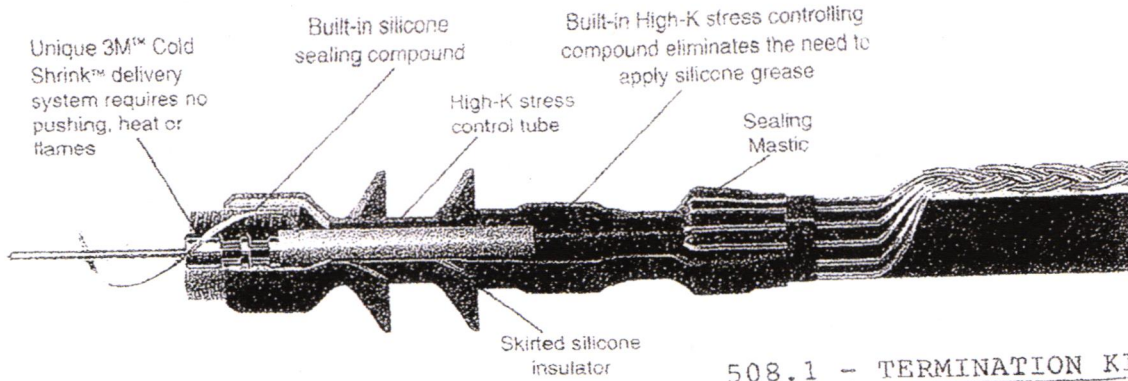

508.1 - TERMINATION KITS

Cold Shrink™ QT-III Outdoor Termination

Kit number	Bil	Cable insulation O.D. range in. (mm)	Conductor size range AWG and komil (mm ²)				
			5kV	8.7kV	15kV	25/28kV	35kV
Shielded Cable Kits*							
7620-S-2	95kV	0.32-0.59 (8,2-15,0)	8-4	8-6			
7621-S-2	95kV	0.44-0.89 (11,2-22,7)	2-3/0	4-2/0			
7622-S-2	110kV	0.64-1.08 (16,3-27,4)	4/0-400	3/0-300	2-4/0 (35-120)		
7692-S-4	150kV	0.64-1.08 (16,3-27,4)	4/0-400	3/0-300	2-4/0 (35-120)	2-1/0 (35-50)	
7693-S-4	150kV	0.72-1.29 (18,3-32,8)	300-500	250-500	2/0-300 (70-150)	2-4/0 (35-120)	
7694-S-4	150kV	0.83-1.53 (21,1-38,9)	500-750	350-700	4/0-500 (120-240)	2/0-250 (70-150)	
7695-S-4	150kV	1.05-1.80 (26,7-45,7)	700-1500	600-1250	500-1000 (240-500)	250-800 (125-400)	
7696-S-4	150kV	1.53-2.32 (38,9-58,9)	1750-2000	1500-2000	1250-2000 (625-1000)	900-1750 (500-800)	
7683-S-8	200kV	0.72-1.29 (18,3-32,8)	300-500	250-500	2/0-300 (70-150)	2-4/0 (35-120)	2-2/0 (35-70)
7684-S-8	200kV	0.83-1.53 (21,1-38,9)	500-750	350-700	4/0-500 (120-240)	2/0-250 (70-150)	2-4/0 (35-120)
7685-S-8	200kV	1.05-1.80 (26,7-45,7)	700-1500	600-1250	500-1000 (240-500)	250-800 (125-400)	3/0-600 (95-325)
7686-S-8	200kV	1.53-2.32 (38,9-58,9)	1750-2000	1500-2000	1250-2000 (625-1000)	900-1750 (500-800)	700-1500 (400-725)
Concentric and Jacketed Concentric Cable Kits**							
7642-S-2	110kV	0.64-1.08 (16,3-27,4)	4/0-400	3/0-300	2-4/0 (35-120)		
7652-S-4	150kV	0.64-1.08 (16,3-27,4)	4/0-400	3/0-300	2-4/0 (35-120)	2-1/0 (35-50)	
7653-S-4	150kV	0.72-1.29 (18,3-32,8)	300-500	250-500	2/0-300 (70-150)	2-4/0 (35-120)	
7654-S-4	150kV	0.83-1.53 (21,1-38,9)	500-750	350-700	4/0-500 (120-240)	2/0-250 (70-150)	
7655-S-4	150kV	1.05-1.80 (26,7-45,7)	700-1500	600-1250	500-1000 (240-500)	250-800 (125-400)	
7656-S-4	150kV	1.53-2.32 (38,9-58,9)	1750-2000	1500-2000	1250-2000 (625-1000)	900-1750 (500-800)	
7663-S-8	200kV	0.72-1.29 (18,3-32,8)	300-500	250-500	2/0-300 (70-150)	2-4/0 (35-120)	2-2/0 (35-70)
7664-S-8	200kV	0.83-1.53 (21,1-38,9)	500-750	350-700	4/0-500 (120-240)	2/0-250 (70-150)	2-4/0 (35-120)
7665-S-8	200kV	1.05-1.80 (26,7-45,7)	700-1500	600-1250	500-1000 (240-500)	250-800 (125-400)	3/0-600 (95-325)
7666-S-8	200kV	1.53-2.32 (38,9-58,9)	1750-2000	1500-2000	1250-2000 (625-1000)	900-1750 (500-800)	700-1500 (400-725)
High Fault Current Cable Kits***							
7652-S-HSG-4	150kV	0.64-1.08 (16,3-27,4)	4/0-400	3/0-300	2-4/0 (35-120)	2-1/0 (35-50)	
7653-S-HSG-4	150kV	0.72-1.29 (18,3-32,8)	300-500	250-500	2/0-300 (70-150)	2-4/0 (35-120)	
7654-S-HSG-4	150kV	0.83-1.53 (21,1-38,9)	500-750	350-700	4/0-500 (120-240)	2/0-250 (70-150)	
7655-S-HSG-4	150kV	1.05-1.80 (26,7-45,7)	700-1500	600-1250	500-1000 (240-500)	250-800 (125-400)	
7656-S-HSG-4	150kV	1.53-2.32 (38,9-58,9)	1750-2000	1500-2000	1250-2000 (625-1000)	900-1750 (500-800)	
7663-S-HSG-8	200kV	0.72-1.29 (18,3-32,8)	300-500	250-500	2/0-300 (70-150)	2-4/0 (35-120)	2-2/0 (35-70)
7664-S-HSG-8	200kV	0.83-1.53 (21,1-38,9)	500-750	350-700	4/0-500 (120-240)	2/0-250 (70-150)	2-4/0 (35-120)
7665-S-HSG-8	200kV	1.05-1.80 (26,7-45,7)	700-1500	600-1250	500-1000 (240-500)	250-800 (125-400)	3/0-600 (95-325)
7666-S-HSG-8	200kV	1.53-2.32 (38,9-58,9)	1750-2000	1500-2000	1250-2000 (625-1000)	900-1750 (500-800)	700-1500 (400-725)

*Each Shielded Cable Kit makes three terminations.

**Each Concentric and Jacketed Concentric Cable Kit makes one termination.

***Each High Fault Current Cable Kit makes one termination.

Revised 1/01

Please contact your local 3M representative for more information.

509 - TERMINATIONS-LOAD SIDE

15 KV PRIMARY CABLE

LOAD SIDE TERMINATIONS:

15 KV PRIMARY CABLE SHALL BE TERMINATED AT THE HIGH VOLTAGE COMPARTMENT OF THE DESIGNATED EQUIPMENT, USING LOAD BREAK ELBOWS.

PRIMARY CABLE ELBOWS SHALL BE OF 15 KV 200 AMPERE, LOAD BREAK CONSTRUCTION.

ELBOWS SHALL BE CONSTRUCTED OF EPDM RUBBER COMPATIBLE WITH ETHYLENE-PROPYLENE RUBBER (EPR) URD PRIMARY CABLE.

ELBOWS SHALL BE CONSTRUCTED WITH HOT-STICK OPERATING EYE, CAPACITANCE TAP, GROUNDING TAP.

ELBOWS SHALL BE SUPPLIED WITH CRIP CONNECTORS FOR NO. 1/0 SOLID ALUM. CONDUCTOR.

THE MINIMUM ACCEPTABLE STANDARD FOR ELBOWS SHALL BE COOPER, CATALOG NO. LE215B05T, AS PRESENTED IN SECTION 509.2 OF THIS SPECIFICATION.

509.1 – TERMINATIONS

ELBOW ARRESTERS AT OPEN POINTS

- ELBOW TYPE ARRESTER SHALL BE LOCATED AT "OPEN POINTS" IN THE LOOP – (1) ONE COOPER CATALOG #3237686C09M PARKING STAND SURGE ARRESTER.
- ALL LOAD BREAK ELBOWS SHALL BE EQUIPPED WITH FAULT INDICATORS AND INSTALLED, PER MANUFACTURER'S DIRECTIONS.
- THE MINIMUM ACCEPTABLE STANDARD FOR THE SURGE ARRESTERS AND FAULT INDICATORS (AS NOTED ABOVE) ARE PRESENTED IN SECTION 509.2 OF THIS SPECIFICATION.

Metal Oxide Parking Stand Surge Arrester

GENERAL

The RTE® Parking Stand Arrester combines metal (zinc) oxide varistor technology with a premolded rubber insulated standoff bushing. The arrester provides overvoltage system protection in an insulated, fully shielded, submersible, deadfront device. The standoff bushing interface conforms to ANSI/IEEE Standard 386—Separable Insulated Connector Systems. The arrester housing provides necessary dead-front safety.

Parking Stand Arresters are used on underground systems in pad-mounted transformers and entry cabinets, vaults, switching enclosures and other installations to provide shielded deadfront arrester protection.

They are designed for use with RTE 200 A loadbreak elbows and other accessories with 200 A loadbreak interfaces per ANSI/IEEE Standard 386 to limit overvoltages to acceptable levels, protect equipment and extend cable life. Parking Stand Arresters provide an economical means of overvoltage protection for energized but parked open point cable runs.

Installation time is reduced as the parking stand arrester replaces a "MOVE" elbow arrester and portable feedthru in this application. See Catalog Section 235-65, for information on the "MOVE" elbow arrester for protection of the other side of loop, radial applications and mid-line protection.

The Parking Stand Arrester is designed to be installed in the parking stand bracket found on the frontplate of a transformer or other apparatus. The molded EPDM rubber body is held in a stainless steel bracket assembly. A stainless steel eyebolt is used to secure the Parking Stand Arrester in the parking stand bracket.

INSTALLATION

No special tools are required. The arrester is placed in a parking stand bracket with a shotgun stick. Refer to Installation Instruction Sheet 5000050704 for details.

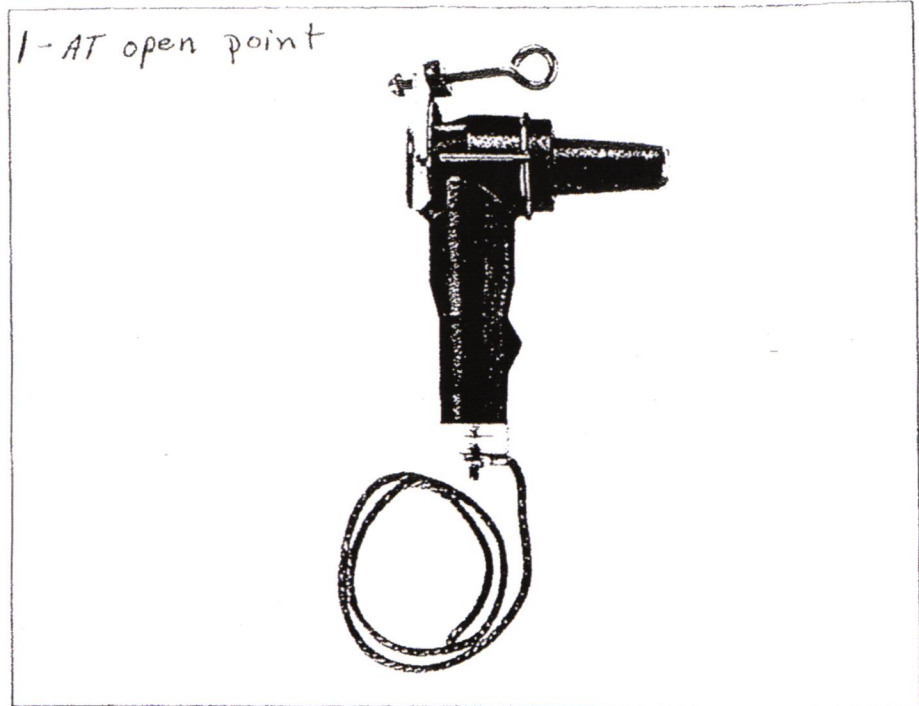

Figure 1.
15 kV Metal Oxide Parking Stand Surge Arrester.

PRODUCTION TESTS

Tests are conducted in accordance with ANSI/IEEE Standard 386.

- Corona Extinction Voltage Level (both on molded rubber body and complete assembly)
- ac 60 Hz 1 Minute Withstand (on molded rubber body only)

Tests are conducted in accordance with RTE requirements.

- Physical Inspection
- Periodic Dissection
- MOV Blocks:
 - Voltage at 1 mA
 - Batch Life Test
- Arrester Assembly: Voltage at 1 mA
- Periodic Fluoroscopic Analysis

TABLE 1
Electrical Ratings and Characteristics

Duty Cycle Voltage Rating (kV)	MCOV (kV)	Equivalent Front-of-Wave (kV)*	Discharge Voltage (kV)**				
			1.5 kA	3 kA	5 kA	10 kA	20 kA
3	2.55	13.7	10.7	12.0	12.8	13.4	15.7
6	5.1	27.4	21.9	24.5	26.2	28.6	34.9
9	7.65	37.4	27.4	29.9	31.4	34.7	38.4
10	8.4	39.7	28.4	30.6	32.9	36.7	40.4
12	10.2	56.1	41.1	44.8	47.1	52.0	57.6
15	12.7	63.0	45.0	49.2	52.5	57.8	66.0
18	15.3	74.8	54.7	59.7	62.7	69.3	76.8
21	17.0	81.7	58.7	64.2	68.2	75.2	85.2

* Equivalent front-of-wave voltage is the expected discharge voltage of the arrester when tested with a 5 kA current surge cresting in 0.5 μs.

** Maximum discharge voltage for an 8/20 μs surge current

Surge Arresters

Electrical Apparatus

235-65

Metal Oxide Elbow Surge Arrester

GENERAL

The RTE® M.O.V.E. Surge Arrester combines metal (zinc) oxide varistor technology in a premolded rubber elbow to provide overvoltage system protection in an insulated, fully shielded, submersible, deadfront device.

The arrester housing interface conforms to ANSI/IEEE Standard 386—Separable Insulated Connector Systems. The arrester housing is molded of RTE EPDM insulating rubber, which provides deadfront safety in a small, shotgun stick operable unit.

M.O.V.E. arresters are used on underground systems in pad-mounted transformer and entry cabinets, vaults, switching enclosures and other installations to provide shielded deadfront arrester protection. They are designed for use with RTE 200 A loadbreak bushings and other accessories with 200 A loadbreak interfaces that conform to ANSI/IEEE Standard 386 to limit overvoltages to acceptable levels, protect equipment and extend cable life.

Installing a M.O.V.E. arrester at the end of a radial system or at both ends of an open point on a loop system provides excellent overvoltage protection. The addition of a second "MOVE" Arrester at the next point upstream provides optimum protection. See Catalog Section 235-68 for information on the "MOV" "Parking Stand Arrester".

INSTALLATION

No special tools are required. The arrester is placed on a 200 A interface by using a shotgun stick. Refer to Installation Instruction Sheet 5000050052 for details.

PRODUCTION TESTS

Tests are conducted in accordance with ANSI/IEEE Standard 386.

- Corona Extinction Voltage Level (both on molded rubber body and complete assembly)
- ac 60 Hz 1 Minute Withstand (on molded rubber body only.)

3238018C09M

1- AT open point

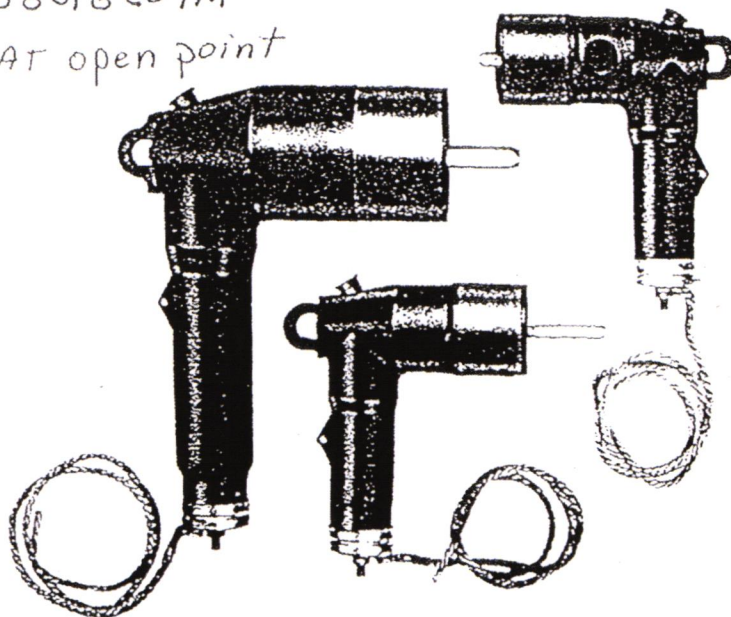

Figure 1.
Metal Oxide Elbow Surge Arresters shown from left to right: 35 kV, 25 kV and 15 kV.

TABLE 1
Electrical Ratings and Characteristics

Duty Cycle Voltage Rating (kV)	MCOV (kV)	Equivalent Front-of-Wave (kV)*	Discharge Voltage (kV)**				
			1.5 kA	3 kA	5 kA	10 kA	20 kA
3	2.55	13.7	10.7	12.0	12.8	13.4	15.7
6	5.1	27.4	21.9	24.5	26.2	28.6	34.9
9	7.65	37.4	27.4	29.9	31.4	34.7	38.4
10	8.4	39.7	28.4	30.6	32.9	36.7	40.4
12	10.2	56.1	41.1	44.8	47.1	52.0	57.6
15	12.7	63.0	45.0	49.2	52.5	57.8	66.0
18	15.3	74.8	54.7	59.7	62.7	69.3	76.8
21	17.0	81.7	58.7	64.2	68.2	75.2	85.2
24	19.5	95.8	69.7	76.1	80.2	88.6	98.8
27	22.0	105.0	75.0	82.0	87.4	96.2	110.0

* Equivalent front-of-wave voltage is the expected discharge voltage of the arrester when tested with a 5 kA current surge cresting in 0.5 μ s.

** Maximum discharge voltage for an 8/20 μ s surge current.

Tests are conducted in accordance with RTE requirements.

- Physical Inspection
- Periodic Dissection
- MOV Blocks:
 - Voltage at 1 mA
 - Batch Life Test
- Arrester Assembly: Voltage at 1 mA
- Periodic Fluoroscopic Analysis

TABLE 2
Performance Test Characteristics*

Description	Characteristics
High Current Short Duration	2 discharges of 40 kA crest
Low Current Long Duration	20 surges of 75 A-2000 microsecond duration
Duty Cycle	22 operations of 5 kA crest 8 x 20 microsecond duration
Thermal Recovery at MCOV	

* Tests were performed in accordance with applicable sections of ANSI C62.11-1987 (Metal Oxide Surge Arresters for Alternating Current Power Circuits) with test levels chosen in accordance with levels found in underground distribution systems.

Loadbreak Apparatus Connectors

COOPER

Cooper Power Systems

Electrical Apparatus

500-10

200 A 15 kV Class Loadbreak Elbow Connector

LE 215B057

GENERAL

The Cooper Power Systems RTE® Loadbreak Elbow connector is a fully-shielded and insulated plug-in termination for connecting underground cable to transformers, switching cabinets and junctions equipped with loadbreak bushings. The elbow connector and bushing insert comprise the essential components of all loadbreak connections.

RTE loadbreak elbows are molded using high quality peroxide-cured EPDM insulation. Standard features include a coppertop connector, tin plated copper loadbreak probe with an ablative arc-follower tip and stainless steel reinforced pulling-eye. An optional capacitive test point, made of corrosion resistant plastic, is available for use with fault indicators (see Catalog Section 320-10).

Wide cable ranges are sized to accept cables insulated at either 175 mil or 220 mil within a given conductor size. The wider cable ranges increase installation flexibility.

The coppertop compression connector is a standard item to transition from the cable to the loadbreak probe. An aluminum crimp barrel is inertia-welded to a copper lug. The aluminum barrel makes the connector easy to crimp and the copper lug ensures a reliable, tight, cool operating connection with the loadbreak probe.

INSTALLATION

Cable stripping and scoring tools, available from various tool manufacturers, are recommended for use when installing loadbreak elbows. After preparing the cable, the elbow housing is pushed onto the cable. The loadbreak probe is threaded into the coppertop connector using the supplied installation tool or an approved equivalent. Use a shotgun stick to perform loadmake and loadbreak operations. See Installation Sheet S500-10-1 for details.



Figure 1. Loadbreak Elbow Connector with test point; also available without test point.

PRODUCTION TESTS

Tests conducted in accordance with ANSI/IEEE Standard 386:

- ac 60 Hz 1 Minute Withstand -34 kV
- Minimum Corona Voltage Level -11 kV
- Test Point Voltage Test

Tests are conducted in accordance with Cooper Power Systems requirements:

- Physical Inspection
- Periodic Dissection
- Periodic Fluoroscopic Analysis

TABLE 1
Voltage Ratings and Characteristics

Description	kV
Standard Voltage Class	15
Maximum Rating Phase-to-Phase	14.4
Maximum Rating Phase-to-Ground	8.3
ac 60 Hz 1 Minute Withstand	34
dc 15 Minute Withstand	53
BIL and Full Wave Crest	95
Minimum Corona Voltage Level	11

Voltage ratings and characteristics are in accordance with ANSI/IEEE Standard 386.

TABLE 2
Current Ratings and Characteristics

Description	Amperes
Continuous Switching	200 A rms 10 operations at 200 A rms at 14.4 kV
Fault Closure	10,000 A rms symmetrical at 14.4 kV after 10 switching operations for 0.17 s
Short Time	10,000 A rms symmetrical for 0.17 s 3,500 A rms symmetrical for 3.0 s

Current ratings and characteristics are in accordance with ANSI/IEEE Standard 386.

510 – CABLE TRENCH

EXCAVATION AND BACKFILL

EVACUATION:

- NO CABLES SHALL BE INSTALLED WITH THE USE OF AN EARTH SLITTER OR PLOW.
- ALL CABLE TRENCHES FOR ALL CABLES SHALL BE EXCAVATED AND SHALL HAVE A MINIMUM WIDTH AND DEPTH AS SHOWN ON THE DRAWINGS AND SPECIFICATIONS.
- ALL TRENCHES SHALL BE KEPT FREE OF WATER BY AN APPROVED METHOD DURING INSTALLATION. IT SHALL BE THE DEVELOPER'S RESPONSIBILITY TO SUPPLY ALL PUMPS, HOSES, HARDWARE, ETC., WHICH SHALL BE REQUIRED TO PERFORM THIS FUNCTION.
- CARE SHALL BE TAKEN TO AVOID EXCESS EXCAVATION.
- ADVANCE TRENCHING SHALL BE PERMITTED ONLY TO THE EXTENT THAT ALL INSTALLATIONS AND BACKFILLING CAN BE COMPLETED IN THAT DAY'S OPERATION.
- WHERE ROCK IS ENCOUNTERED, EXCAVATION SHALL BE TO A DEPTH OF SIX (6) INCHES GREATER THAN THE DIMENSIONS SPECIFIED. THIS EXTRA DEPTH SHALL BE BACKFILLED WITH SELECT BORROW OR SAND AND COMPACTED BEFORE ANY CABLE IS INSTALLED IN THE TRENCH.
- THE DEVELOPER SHALL NOTIFY THE BOARD OF PUBLIC WORKS IMMEDIATELY IF SOFT OR SPRING CONDITIONS ARE DISCOVERED DURING EXCAVATION. WORK IN SUCH AREAS SHALL IMMEDIATELY TERMINATE UNTIL INSTRUCTIONS ARE RECEIVED FROM THE BOARD OF PUBLIC WORKS.

BACKFILLING:

- ALL TRENCHES SHALL BE PROPERLY BACKFILLED PRIOR TO CESSATION OF DAILY WORK PERIODS.
- BACKFILLING OF CONDUCTOR TRENCHES SHALL BE IN ACCORDANCE WITH THE TRENCH DETAILS SHOWN ON THE DRAWINGS AND SPECIFICATIONS.
- ALL EXCAVATED MATERIALS NOT SUITABLE OR REQUIRED FOR BACKFILL SHALL BE DISPOSED OF BY THE DEVELOPER.
- ALL EXCAVATIONS SHALL BE BACKFILLED AND THOROUGHLY COMPACTED AT THE EXPENSE OF THE DEVELOPER.
- IT SHALL BE THE RESPONSIBILITY OF THE DEVELOPER TO NOTIFY THE BOARD OF PUBLIC WORKS, TWENTY-FOUR (24) HOURS IN ADVANCE OF ANY CABLE LAYING OR BACKFILL.

510 – CABLE TRENCH
EXCAVATION AND BACKFILL (CONTINUED)

- NO CABLE SHALL BE INSTALLED OR TRENCHES BACKFILLED, EXCEPT IN THE PRESENCE OF AN INSPECTOR APPOINTED BY THE BOARD OF PUBLIC WORKS.
- PIECES OF SCRAP CABLE SHALL NOT BE BURIED IN THE TRENCH AS A MEANS OF DISPOSAL.
- ALL CONDUCTORS SHALL BE COMPLETELY ENCASED IN A LAYER OF EXCAVATED MATERIAL FREE OF DEBRIS IN EXCESS OF ONE (1) INCH IN DIAMETER, SIX (6) INCHES BELOW AND SIX (6) INCHES ABOVE ANY CONDUCTORS.
- EARTH CONTAINING FROST SHALL BE EXCLUDED FROM BACKFILL.
- ALL BACKFILL SHALL BE PLACED IN LIFTS EIGHT (8) INCHES OR LESS IN THICKNESS.
- PRIOR TO BACKFILLING AROUND POLE FOUNDATIONS, ALL FORMS, TRASH, DEBRIS, ETC., SHALL BE CLEARED AWAY AND LOOSE EARTH REMOVED TO SOLID GROUND. APPROVED BACKFILL SHALL BE PLACED AROUND FOUNDATION IN LAYERS NOT EXCEEDING EIGHT (8) INCHES, EACH LAYER SHALL BE MOISTENED (IF REQUIRED) AND MECHANICALLY TAMPED TO 90 PERCENT (95%) OF MAXIMUM DRY DENSITY AT OPTIMUM MOISTURE CONTENT.

511 – PRIMARY CABLE IDENTIFICATION

- EACH PRIMARY CABLE IN TRANSFORMERS WILL BE MARKED AT ELBOW WITH IDENTIFICATION TAGS REFERENCE TO WHAT NUMBER TRANSFORMER THEY CAME FROM AND WHAT NUMBER TRANSFORMER THEY ARE GOING TO INCLUDING IDENTIFICATION OF THE BUSHING THEY ARE ON WITH PHASE LETTER. (SEE 511-1.)
- ALL MARKINGS TO BE WITH PERMANENT MARKER PEN BLACK.
- ALL CABLES AT POLE TO BE MARKED WITH PHASE LETTER.
- MINIMUM ACCEPTABLE STANDARDS FOR CABLE LABEL MATERIALS ARE PRESENTED IN SECTION 511.2 OF THIS SPECIFICATION.

511.1 - PRIMARY CABLE IDENTIFICATION ILLUSTRATION

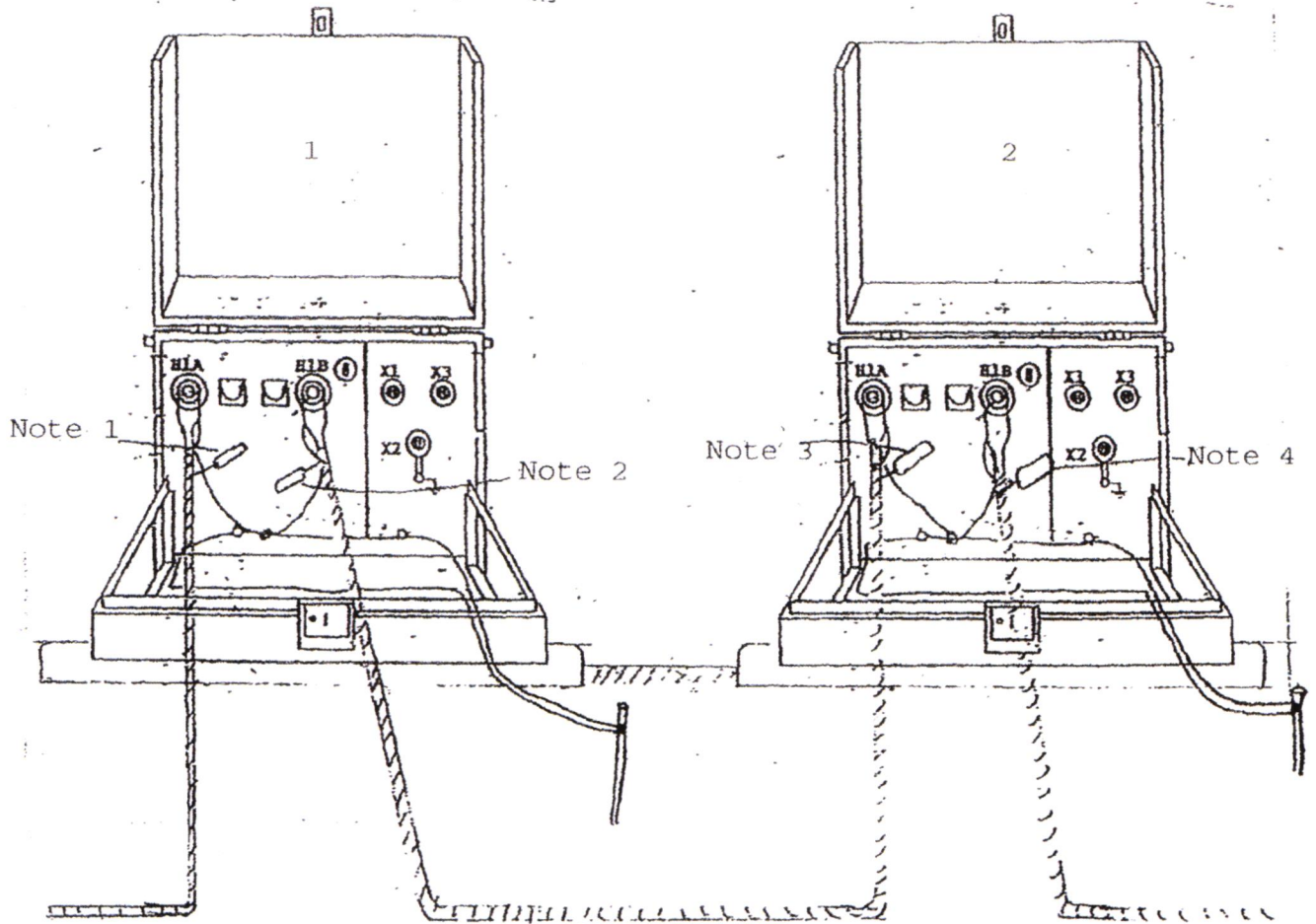

Notes

- 1 From Pole A Ph
- 2 To Xfmr 2 H1A A Ph
- 3 From Xfmr 1 H1B A Ph
- 4 To Xfmr 3 H1A A Ph



AMERICAN SAFETY UTILITY CORPORATION
AS-U-C the need for Safety Products . . .

1808 E. DIXON BLVD.

SHELBY, N.C. 28150

FlagTag™ cable label system



Model 609 Cable Tag, 4" x 1 1/2" writing area, with strap to pass around cable up to 1 1/2" O.D.

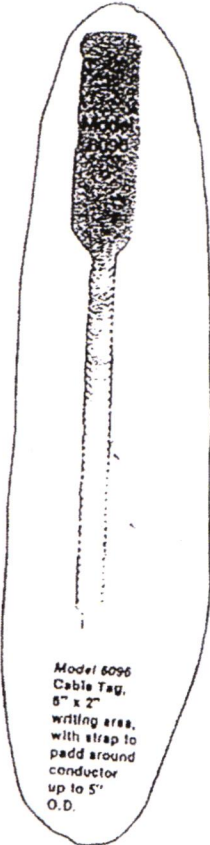

Model 6096 Cable Tag, 8" x 2" writing area, with strap to pass around conductor up to 5" O.D.

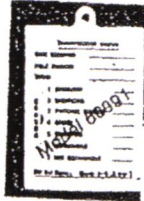

#00991
 Transformer Status
 Date Removed _____
 Pole Number _____
 Town _____
 R 1 Overload _____
 E 2 Lightning _____
 A 3 Physical Damage _____
 S 4 Other _____
 O 5 Unknown _____
 H 6 Repairable _____
 7 Not Repairable _____
 Fill Out Above;
 Check 1-6 & 7

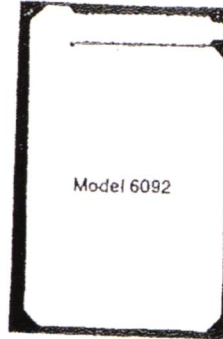

Model 6092



Model 6094

Mini-Tags, Model 6093 (3 1/4" green triangle), Model 6093 (3 1/4" red round) and Model 6094 (3" white square) with grommated holes for attaching to equipment, cables, etc.

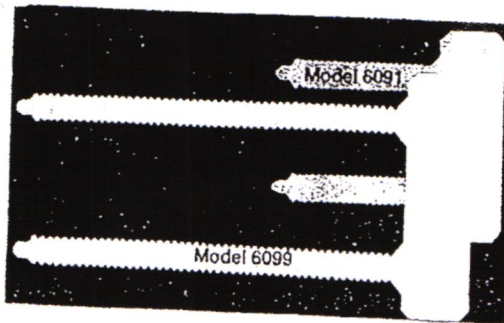

Model 6099 Jumbo Cable Tag, 8" x 2" writing area, with 2 12" straps to pass around conductor up to 6" O.D.

Model 6091 Jumbo Cable Tag, 6" x 2" writing area, with 2 straps to pass around cable up to 1 1/2" O.D.



Model 6098 T-Shaped Cable Tag, 4" x 1 1/2" writing area, with strap to pass around cable up to 1 1/2" O.D.



Sharpie Marking Pen

Flag Tag™ Label System includes a variety of easy to attach bright colored tags that can be marked with a long lasting Sharpie marking pen. You can order any one of five cable tags, a vault map, a transformer status tag or three Mini-Tags.

Flag Tag™ Test Results

Both the Flag Tag™ material and the Sharpie marking pen have been tested for long periods of time under extreme conditions to assure that notations will remain legible indefinitely. These tests include boiling water, electrical joint compound, fertilizer, silicon lubricant, transformer fluid, and year-around weather. Exposure to direct sunlight for long periods of time (1-2 years) may fade the ink or plastic colors. (Test results available on special request.)



AMERICAN SAFETY UTILITY CORPORATION
 AS-U-C the need for Safety Products ...

1808 E. DIXON BLVD.

SHELBY, N.C. 28150



Woven Tape	Catalog No.	Size
black & yellow roll	C91172 C91176	3/4"x100' 2"x200'

Thank You...
 I APPRECIATE
 YOUR NOT SMOKING
 HERE

#909 (6" x 9") pressure sensitive
 white background with red letters

REPORT
ALL INJURIES
TO YOUR
FOREMAN

#308 (9" x 12") pressure sensitive red background black letters.

UNDERGROUND TAPES

3" x 1000 Ft.

#CBCTVLB-3-U
 CAUTION BURIED CABLE T.V. LINE BELOW

#CBELB-3-U
 CAUTION BURIED ELECTRIC LINE BELOW

#CBGLB-3-U
 CAUTION BURIED GAS LINE BELOW

#CBTLB-3-U
 CAUTION BURIED TELEPHONE LINE BELOW

#CBWLB-3-U
 CAUTION BURIED WATER LINE BELOW

COLOR CODES

FOR

UTILITY LOCATING

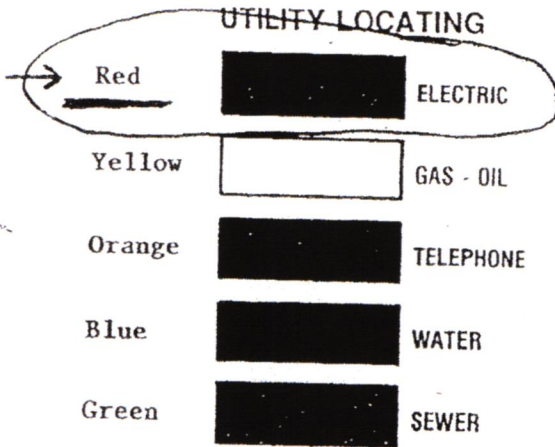

UNDERGROUND TAPES

6" x 1000 Ft.

→ #CBELB-6-U
 CAUTION BURIED ELECTRIC LINE BELOW

#CBSLB-6-U
 CAUTION BURIED SEWER LINE BELOW

BARRICADE
 3" x 1000 Ft.

#CCC-3-B CAUTION CAUTION CAUTION
 #FLDNC-3-B FIRE LINE DO NOT CROSS
 #PLDNC-3-B POLICE LINE DO NOT CROSS

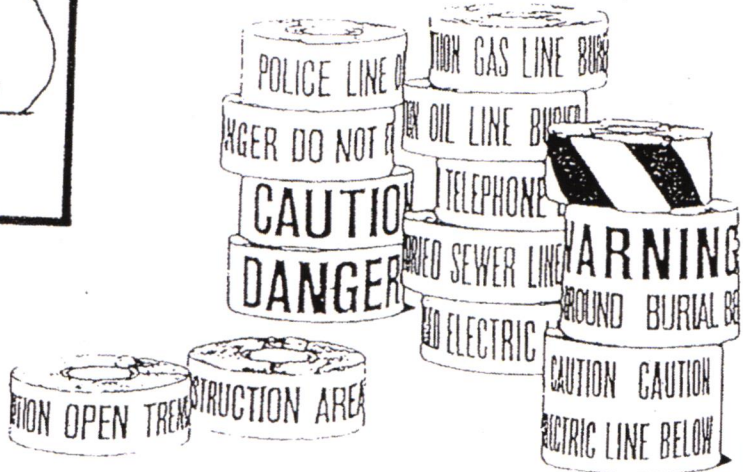

600 – SECONDARY UNDERGROUND DISTRIBUTION

- 601 TRANSFORMER CONNECTIONS
- 601.1 PADMOUNT ADAPTER CONNECTOR
- 602 SECONDARY PEDESTAL SPECIFICATION
- 602.1 SECONDARY SERVICE ENCLOSURE
- 603 SECONDARY PEDESTAL CONNECTIONS
- 604 CABLE TRENCH WITH 15 KV. SINGLE PHASE DISTRIBUTION
- 605 SECONDARY CABLE SPECIFICATION
- 606 SECONDARY CABLE AND STREET LIGHTING ACCEPTANCE TEST
- 607 CABLE TRENCH EXCAVATION/BACKFILL
- 608 SECONDARY CABLE IDENTIFICATION

SECONDARY CONNECTION

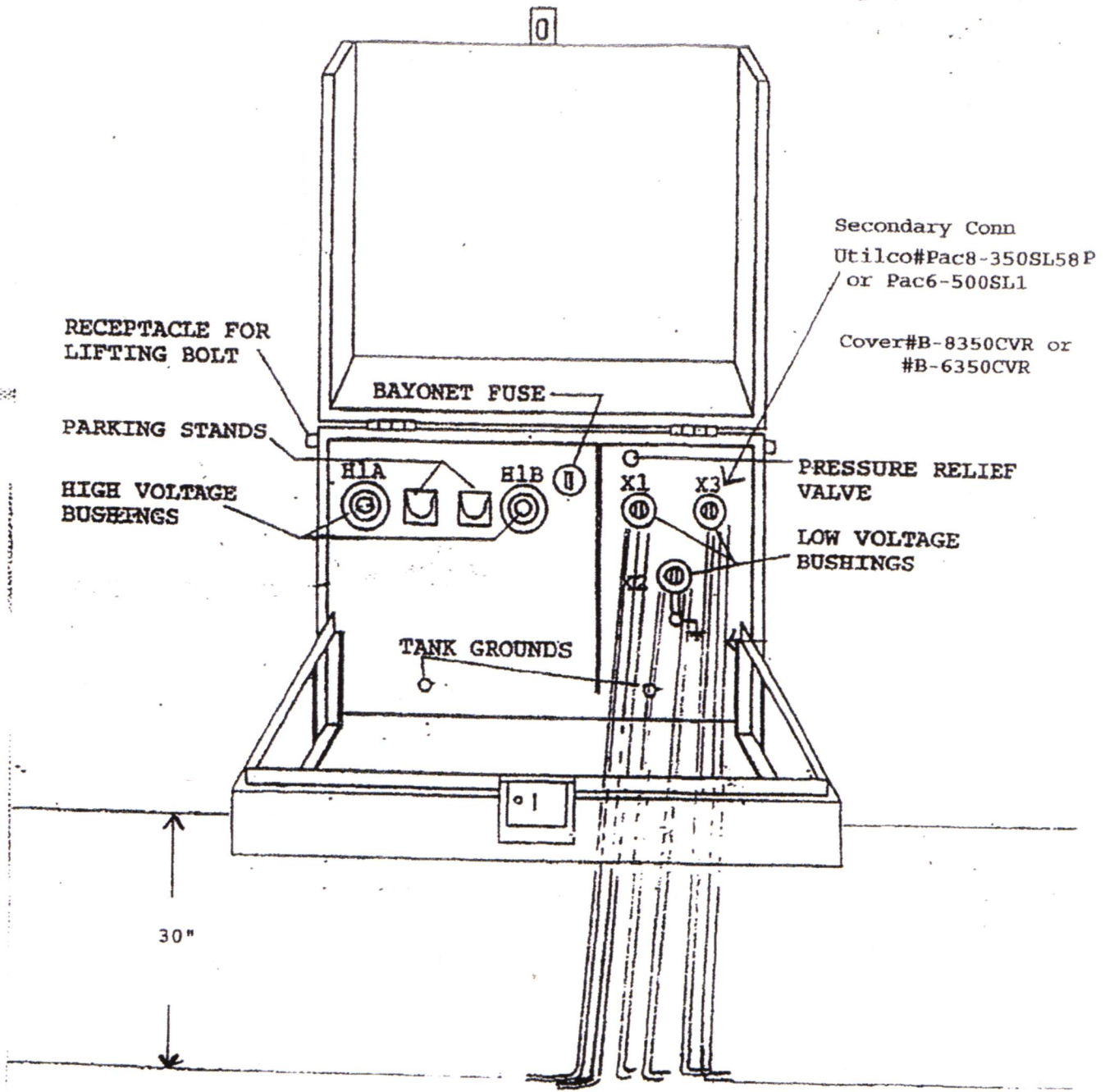

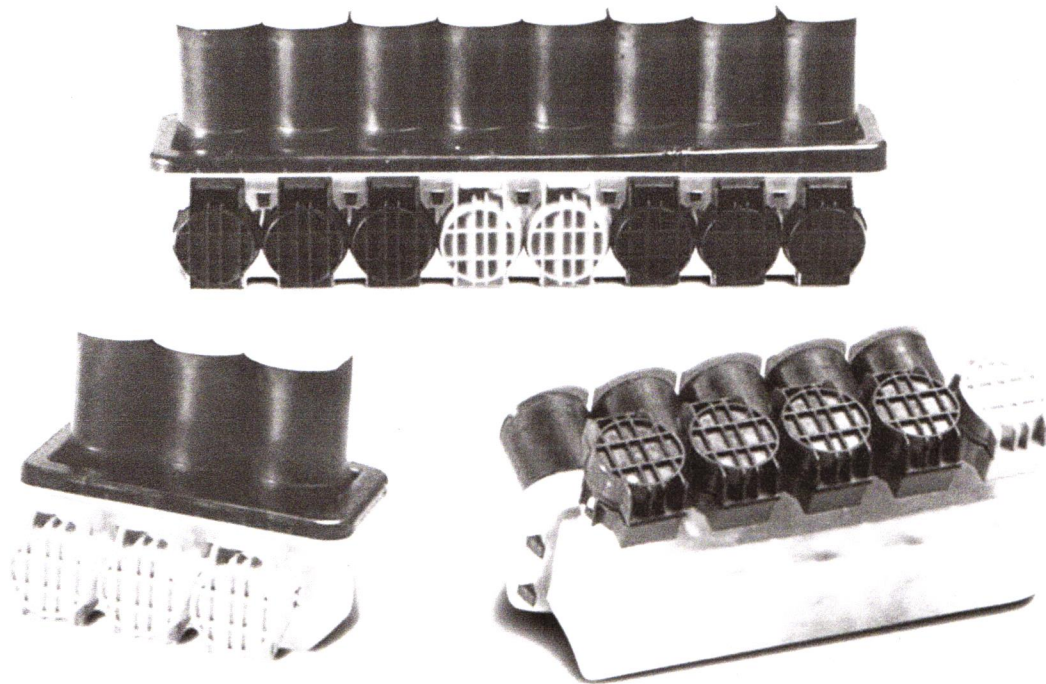

- Resistente a la corrosión
- No hay partes sueltas. Los conectores Gelport son de una pieza.
- Los puertos de entrada de cables rellenos con gel proporcionan un sellado de cables confiable.
- El gel sellante PowerGel proporciona un conexión confiable y hermetico en entornos exigentes.
- La carcasa robusta resistente a los impactos y a instalaciones difíciles.
- La parte trasera transparente proporciona una indicación visual positiva sencilla de la posición del cable en el conector.

El sistema de conexión GelPort TE Connectivity (TE) representa un producto revolucionario para los conectores secundarios. Solo prepare el cable e indrozcalo en el interior del puerto relleno con gel. El cable se encapsula en el gel y queda sellado instantáneamente. Instalación rápida y sencilla siempre. Es así de fácil.

El sellante en gel PowerGel fue desarrollado específicamente para la industria de energía eléctrica. Está compuesto por un elastómero de silicona combinado químicamente con aceite de silicona. El PowerGel es hidrofóbico y proporciona un excelente sello contra la humedad en un amplio rango de temperaturas de operación (-40° C a 95° C). Es compatible con diferentes tipos de aislamiento y grasas desoxidantes para conectores, y tiene excelentes propiedades aislantes.



MCM 130/100-Werk

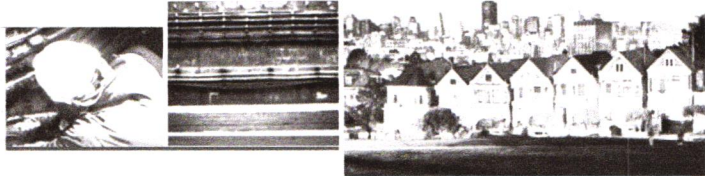

Descripción	Visor transparente	Número de puertos de cables	Rango de uso de conductores (mm ²)	Longitud en pulgadas (mm)	Ancho en pulgadas (mm)	Altura en pulgadas (mm)
GPRT-350-3P	-C	3	14 - 350 (2 - 150)	4,60 (117)	3,825 (97)	3,50 (89)
GPRT-350-4P	-C	4	14 - 350 (2 - 150)	5,85 (149)	3,825 (97)	3,50 (89)
GPRT-350-5P	-C	5	14 - 350 (2 - 150)	7,10 (180)	3,825 (97)	3,50 (89)
GPRT-350-6P	-C	6	14 - 350 (2 - 150)	8,35 (212)	3,825 (97)	3,50 (89)
GPRT-350-8P	-C	8	14 - 350 (2 - 150)	10,85 (276)	3,825 (97)	3,50 (89)
GPRT-350/4P-500/1P	-C	5 híbrido		7,10 (180)	3,825 (97)	3,50 (89)
		4	14 - 350 (2 - 150)			
		1	6 - 500 (16 - 250)			
GPRT-350/6P-500/2P	-C	8 Hybrid		10,85 (276)	3,825 (97)	3,50 (89)
		6	14 - 350 (2 - 150)			
		2	6 - 500 (16 - 250)			
GPRT-500-3P	-C	3	6 - 500 (16 - 250)	4,6 (117)	3,825 (97)	3,50 (89)
GPRT-500-4P	-C	4	6 - 500 (16 - 250)	5,85 (149)	3,825 (97)	3,50 (89)
GPRT-500-5P	-C	5	6 - 500 (16 - 250)	7,1 (180)	3,825 (97)	3,50 (89)
GPRT-500-6P	-C	6	6 - 500 (16 - 250)	8,35 (212)	3,825 (97)	3,50 (89)
GPRT-500-8P	-C	8	6 - 500 (16 - 250)	10,85 (276)	3,825 (97)	3,50 (89)

Nota: Para pedir la parte trasera transparente, agregue "-C" al número de catálogo

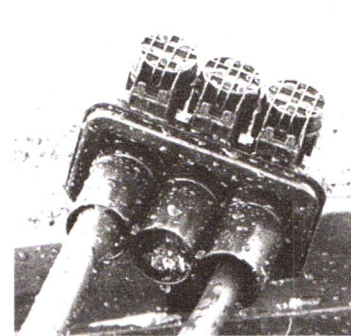
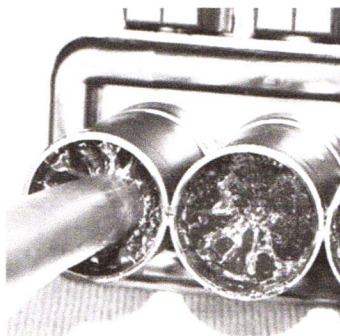
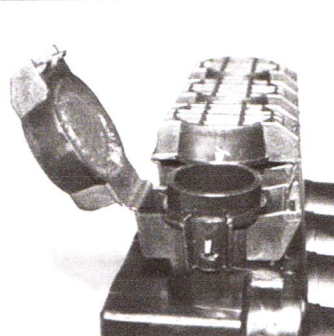

Unidad completa

ANSI C119.1, 2002, informe:
EDR-5379, EDR-5409,
EDR-5427

Conector

ANSI C119.4, 2003, informe:
502-47264, 502-47302,
502-47308

Resistencia a productos químicos

ASTM D543, resistente a los siguientes líquidos: ácido sulfúrico, sulfato de sodio, cloruro de sodio, hidróxido de sodio, etilenglicol

Resistencia a rayos UV

ASTM G-53-95,
ASTM-D-638-95

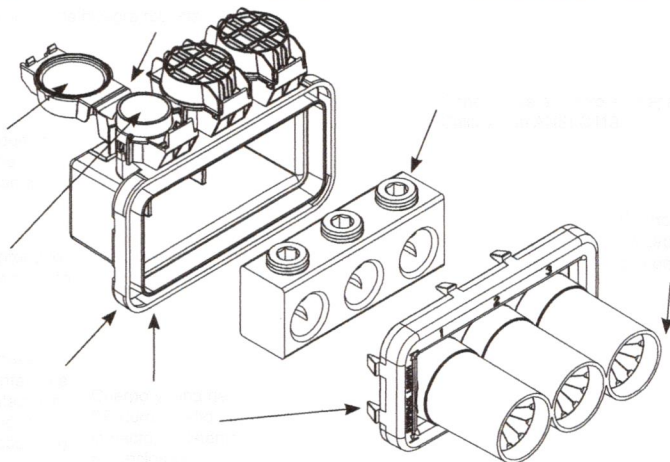

PARA MÁS INFORMACIÓN:

Centros de Asistencia Técnica de TE

EEUU:	+1 800 327 6996
Francia:	+33 380 583 200
Reino Unido:	+44 0870 870 7500
Alemania:	+49 896 089 903
España:	+34 916 630 400
Italia:	+39 333 250 0915
Benelux:	+32 16 351 731
Canadá:	+1 (905) 475-6222
México:	+52 (0) 55-1106-0800
Latinoamérica/ Sudamérica	+54 (0) 11-4733-2200
China:	+86 (0) 400-820-6015

©2015, 2016, 2017 Familia de empresas de TE Connectivity Ltd. Todos los derechos reservados. EPP-2619-DDS-5/16-EN-AMS-GelPort-Raychem E213

Raychem, TE, TE Connectivity y el (logotipo) TE Connectivity son marcas registradas. Otros logotipos, productos y nombres de empresas pueden ser marcas comerciales de sus respectivos propietarios. Aunque TE ha hecho todo lo razonablemente posible para asegurar la exactitud de la información de este folleto, TE no garantiza que se encuentre libre de errores, ni de otro modo declara, garantiza o asegura que la información sea exacta, correcta, confiable o actual. TE se reserva el derecho de realizar ajustes a la información contenida en este documento en cualquier momento sin previo aviso. TE renuncia expresamente a toda garantía implícita con respecto a la información contenida en este documento, incluyendo, pero sin limitación, cualquier garantía implícita de comerciabilidad o idoneidad para un propósito en particular. Las dimensiones que aparecen en este catálogo son únicamente como referencia y están sujetas a cambio sin previo aviso. Las especificaciones están sujetas a cambios sin previo aviso. Consulte con TE las dimensiones y especificaciones de diseño más recientes.

SCREW: SEE CHART	MATERIAL: PLASTISOL/ ALUMINUM	REV: A	ECM INDUSTRIES	
END ITEM: SEE CHART	PLATING: BAR: WAX	DRAWN BY: ER	SCALE: 1:1	800-776-9775 www.ilsc.com
INFORMATION SHEET: FORM 18	MARKING: NONE	DATE: 8/31/2020	SIZE: B	DWG NO: M7065
				SHEET: 1 OF 1

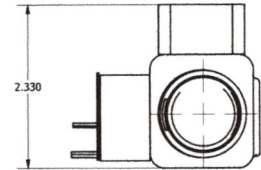
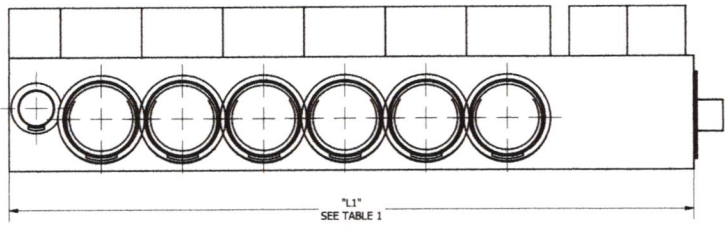
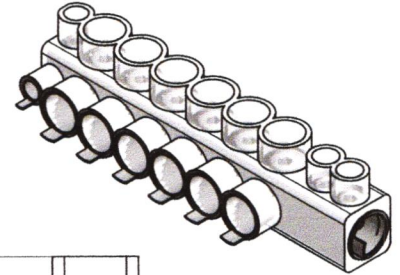
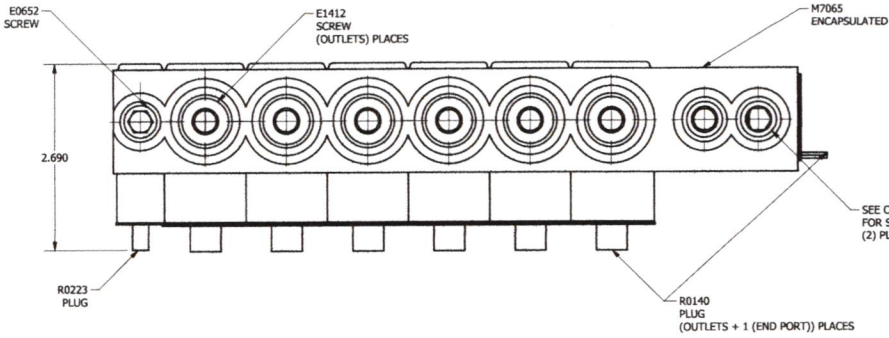

SEE CHART FOR SCREW (2) PLACES

END ITEM	ASSY NUMBER	SCREW	OUTLETS	L1
UPTF4-500ESLARP	M7065B04W	E0608	4	7.508
UPTF6-500ESLARP	M7065B06W	E0608	6	9.844
UPTF8-500ESLARP	M7065B08W	E0608	8	12.180
UPTF4-500ESLAR	M7065B04W	E0608	4	7.508
UPTF6-500ESLAR	M7065B06W	E0608	6	9.844
UPTF8-500ESLAR	M7065B08W	E0608	8	12.180
UPTF4-500ESLRP	M7065B04W	E1490	4	7.508
UPTF6-500ESLRP	M7065B06W	E1490	6	9.844
UPTF8-500ESLRP	M7065B08W	E1490	8	12.180
UPTF4-500ESLR	M7065B04W	E1490	4	7.508
UPTF6-500ESLR	M7065B06W	E1490	6	9.844
UPTF8-500ESLR	M7065B08W	E1490	8	12.180

THIS PRINT AND INFORMATION THEREIN IS CONFIDENTIAL AND PROPRIETARY AND IS THE PROPERTY OF ECM INDUSTRIES. IT IS NOT TO BE COPIED OR REPRODUCED WITHOUT WRITTEN PERMISSION FROM ECM INDUSTRIES.

UTILCO**Aluminum Stud Mounted Padmount Adaptor
Connectors - Dual Rated - For Threaded Stud Padmounts****TYPE
PAC****Features**

- Manufactured from high strength 6061-T6 aluminum alloy
- Rated for 600 volts
- Range taking
- Insulating cover available
- Clear plated
- Meets or exceeds ANSI C119.4 Class A specifications

Benefits

- Suitable for use with either copper or aluminum conductors
- Ensures reliability
- Reduces inventory
- Eliminates taping
- Provides low contact resistance
- Industry standard

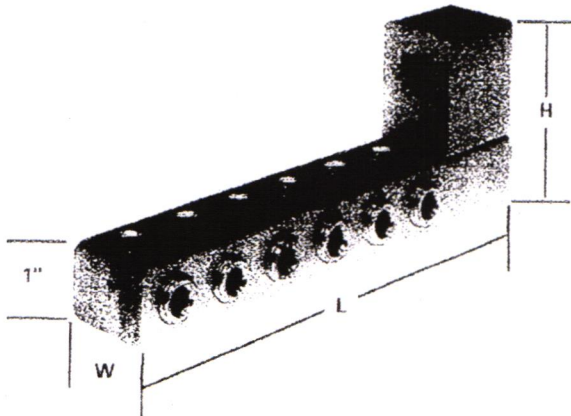
A

Catalog Number	Wire Range	Number of Ports	For Transformer Stud	Stud Hole Size	Street Light Tap	Connector Dimensions			Cover Catalog Number
						L	H	W	
PAC4-350	350kcmil-10	4	5/8-11, 1-14	5/8	No	5-3/4	2-13/16	1-1/4	B-6350CVR
PAC6-350	350kcmil-10	6	5/8-11, 1-14	5/8	No	7-3/4	2-13/16	1-1/4	B-6350CVR
PAC8-350	350kcmil-10	8	5/8-11, 1-14	5/8	No	9-3/4	2-13/16	1-1/4	B-8350CVR
PAC6-350SL1	350kcmil-10	6	5/8-11, 1-14	1	Yes	7-3/4	2-13/16	1-1/4	B-6350CVR
PAC8-350SL1	350kcmil-10	8	5/8-11, 1-14	1	Yes	9-3/4	2-13/16	1-1/4	B-8350CVR
PAC4-350SL58	350kcmil-10	4	5/8-11, 1-14	5/8	Yes	5-3/4	2-13/16	1-1/4	B-6350CVR
PAC6-350SL58	350kcmil-10	6	5/8-11, 1-14	5/8	Yes	7-3/4	2-13/16	1-1/4	B-6350CVR
PAC8-350SL58	350kcmil-10	8	5/8-11, 1-14	5/8	Yes	9-3/4	2-13/16	1-1/4	B-8350CVR
PAC6-500SL1	500kcmil-6	6	5/8-11, 1-14	1	Yes	9-1/8	2-13/16	1-5/8	B-6350CVR

See page 225 for cover information

PAC OPTIONS:

P - Inhibitor

Example:**PAC6-350SL1P**

Street Light Tap

1" Stud Mount

Inhibitor Must be LAST

602- SECONDARY PEDESTAL SPECIFICATIONS

PEDESTALS REQUIRED FOR LOW VOLTAGE DISTRIBUTION SHALL BE OF THE ABOVEGROUND TYPE AND SHALL BE NORDIC PSP-91330 MG

EACH PEDESTAL SHALL BE LABELED WITH ELECTRIC ON OUTSIDE COVER.

REVISIONS			
REV.	DESCRIPTION	DATE	APPROVED
REL-01		1/13/2006	

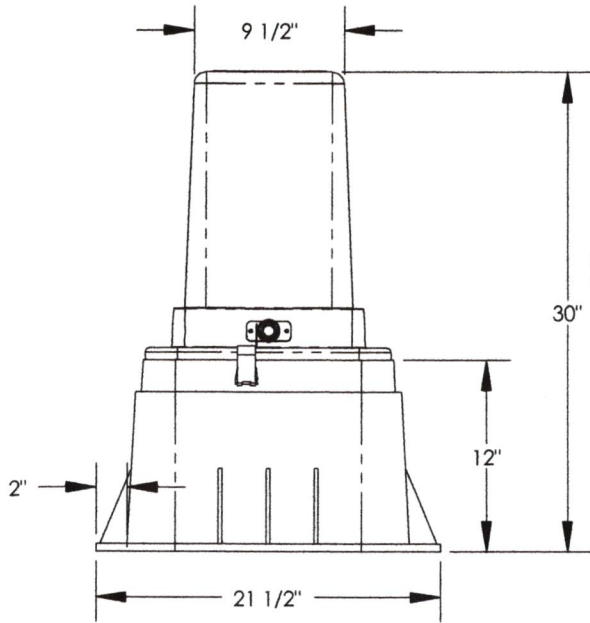
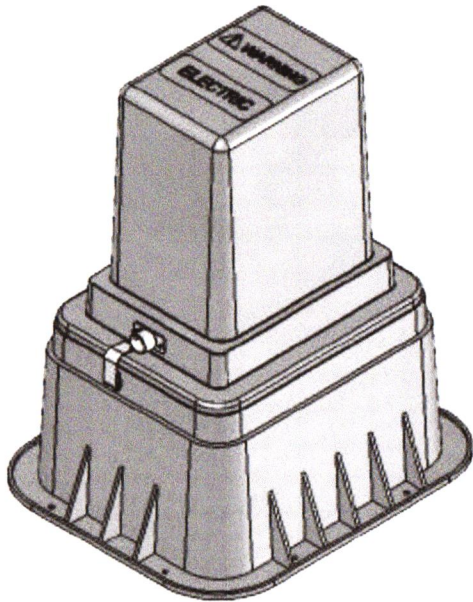
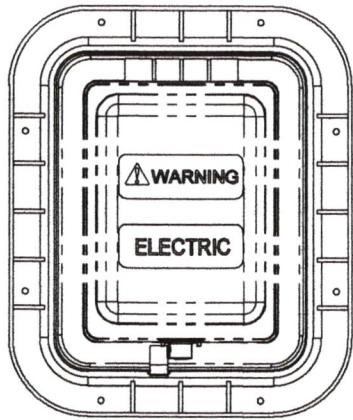

SS Locking hardware
w/ Pentahead Bolt

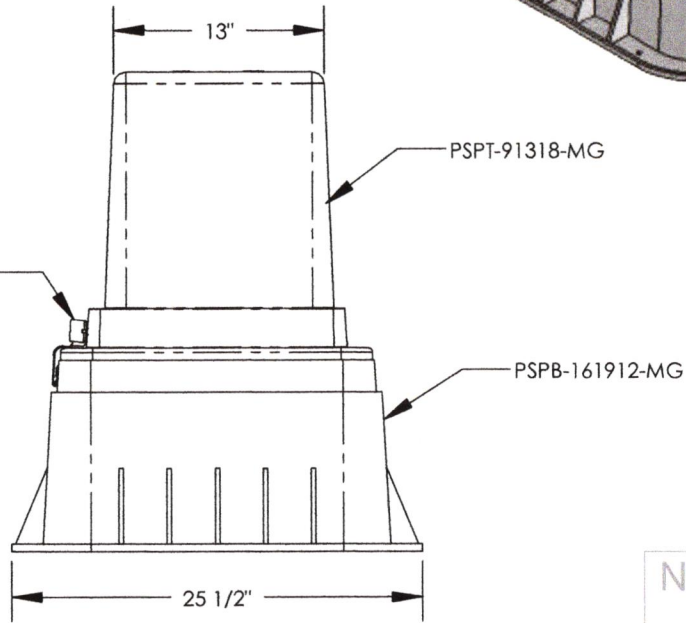

Nordic Fiberglass, Inc.
 21415 US Hwy 75 NW, Warren, MN 56762
 www.nordicfiberglass.com
 218-745-5095 ph. -- 218-745-4990 fax

PROPRIETARY AND CONFIDENTIAL
 THE INFORMATION CONTAINED IN THIS DRAWING IS THE SOLE PROPERTY OF
 NORDIC FIBERGLASS, INC. ANY REPRODUCTION IN PART OR AS A WHOLE
 WITHOUT THE WRITTEN PERMISSION OF NORDIC FIBERGLASS, INC. IS PROHIBITED.

Customer Name: N/A			MATERIAL		PSP-91330-MG	
DIMENSIONS ARE IN INCHES			DATE	SIZE	ITEM ID:	REV.
TOLERANCES: ANGLES ± 1°			01/12/06	A	03514.00	REL-01
FRACTIONAL ± 1/2			DRAWN	NAME		
ONE PLACE DECIMAL ±.060			P.J.W.			
TWO PLACE DECIMAL ±.030			CHECKED			
THREE PLACE DECIMAL ±.015						
					SCALE 1:12	SHEET 1 OF 1

603 – SECONDARY PEDESTAL CONNECTION

LEAVE CABLES 18 INCHES ABOVE FRONT LIP, TAPE WITH THREE (3) LAYERS OF 130C OR SCOTCH 33 TAPE.

MARK CABLES WITH COLORED WIRE TIES CORRESPONDING TO TRANSFORMER ENDS.

604 - CABLE TRENCH WITH 15KV SINGLE PHASE DISTRIBUTION

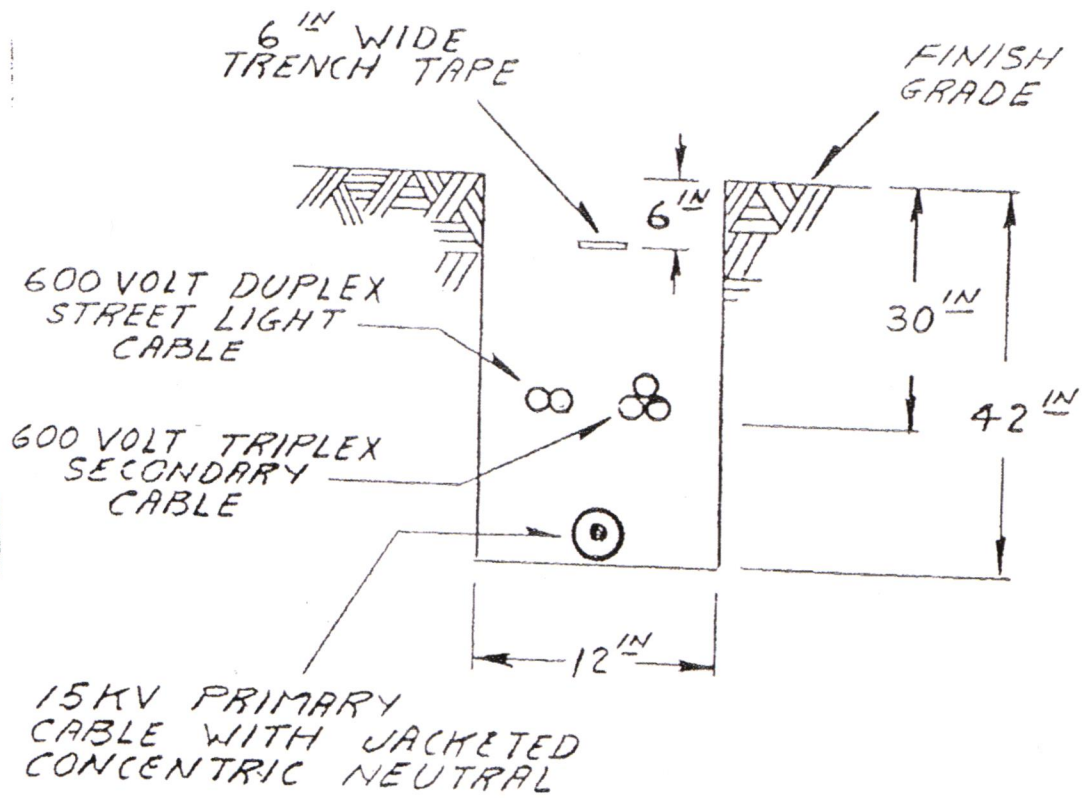

605 – SECONDARY CABLE SPECIFICATION

ALL SECONDARY CABLE INTENDED FOR UNDERGROUND DISTRIBUTION IN CONDUIT OR DIRECT BURIAL SHALL HAVE THE FOLLOWING MINIMUM ACCEPTABLE CHARACTERISTICS AND PERFORMANCE PER PRODUCT DATA PRESENTED IN SECTION 605.1 OF THIS SPECIFICATION:

- DIRECT BURIAL.
- 600 VOLT, XLPE INSULATION, 2 LAYER ABRASION RESISTANT SUPERTUF CROSSLINKED POLYETHYLENE TRIPLEXED CABLE CONFIGURATION.
- PHASE CONDUCTORS: THE CONDUCTOR SIZE SHALL BE MINIMUM 4/0 AWG STRANDED ALUMINUM ALLOY TYPE 1350.
- NEUTRAL CONDUCTORS: STRANDED ALUMINUM, FULL RATED, MINIMUM 2/0.
- CONDUCTOR SIZES FOR APPLICATIONS ABOVE THE MINIMUM RATING FOR 4/0 CABLE SHALL BE SIZED PER NEC ARTICLE 310.
- INSULATION: BOTH PHASE CONDUCTORS AND THE NEUTRAL CONDUCTOR SHALL HAVE AN INSULATION THICKNESS OF NOT LESS THAN 80 MILS. TWO LAYER INSULATION, INNER LAYER OF LOW-DENSITY POLYETHYLENE, OUTER LAYER OF BLACK MEDIUM/HIGH DENSITY POLYETHYLENE.
- NEUTRAL CONDUCTOR: THE NEUTRAL CONDUCTOR INSULATION SHALL BE READILY IDENTIFIABLE WITH AN EXTRUDED YELLOW STRIPE.
- SPECIFICATIONS: UL NO. 854, ICEA P-8-570, ASTM B-231.
- MANUFACTURER: MINIMUM ACCEPTABLE STANDARD PER SECTION 605.1.

606 – SECONDARY AND STREET LIGHTING

CABLE ACCEPTANCE TEST

ACCEPTANCE TESTING OF ANY CABLE SHALL BE PERFORMED WITH ALL CABLE TERMINATIONS IN PLACE BUT DISCONNECTED FROM THE SYSTEM.

CABLE TESTING SHALL BE PERFORMED BY A CERTIFIED TESTING AGENCY APPROVED BY THE CITY OF LEWES, BOARD OF PUBLIC WORKS.

CABLES RATED 600 VOLTS OR LESS SHALL NOT BE HIGH POTENTIAL TESTED; BUT SHALL BE ACCEPTANCE TESTED AT 1000 VOLTS DC FOR ONE (1) MINUTE.

WARNING

THE APPLICATION OF SERVICE VOLTAGE OR TEST VOLTAGE TO A CABLE MAY CAUSE A VOLTAGE RECOVERY OF SUFFICIENT MAGNITUDE TO CREATE A HAZARD. EXTREME CARE MUST BE TAKEN TO PROPERLY AND COMPLETELY DISCHARGE THE CABLE AFTER COMPLETION OF TESTING.

607 – CABLE TRENCH

EXCAVATION AND BACKFILL

EXCAVATION:

- NO CABLES SHALL BE INSTALLED WITH THE USE OF AN EARTH SLITTER OR PLOW.
- ALL CABLE TRENCHES FOR ALL CABLES SHALL BE EXCAVATED AND SHALL HAVE A MINIMUM WIDTH AND DEPTH AS SHOWN ON THE DRAWINGS AND SPECIFICATIONS.
- ALL TRENCHES SHALL BE KEPT FREE OF WATER BY AN APPROVED METHOD DURING INSTALLATION. IT SHALL BE THE DEVELOPER'S RESPONSIBILITY TO SUPPLY ALL PUMPS, HOSES, HARDWARE, ETC., WHICH SHALL BE REQUIRED TO PERFORM THIS FUNCTION.
- CARE SHALL BE TAKEN TO AVOID EXCESS EXCAVATION.
- ADVANCE TRENCHING SHALL BE PERMITTED ONLY TO THE EXTENT THAT ALL INSTALLATIONS AND BACKFILLING CAN BE COMPLETED IN THAT DAY'S OPERATION.
- WHERE ROCK IS ENCOUNTERED, EXCAVATION SHALL BE TO A DEPTH OF SIX (6) INCHES GREATER THAN THE DIMENSIONS SPECIFIED. THIS EXTRA DEPTH SHALL BE BACKFILLED WITH SELECT BORROW OR SAND AND COMPACTED BEFORE ANY CABLE IS INSTALLED IN THE TRENCH.
- THE DEVELOPER SHALL NOTIFY THE BOARD OF PUBLIC WORKS IMMEDIATELY IF SOFT OR SPRING CONDITIONS ARE DISCOVERED DURING EXCAVATION. WORK IN SUCH AREAS SHALL IMMEDIATELY TERMINATE UNTIL INSTRUCTIONS ARE RECEIVED FROM THE BOARD OF PUBLIC WORKS.

BACKFILLING:

- ALL TRENCHES SHALL BE PROPERLY BACKFILLED PRIOR TO CESSATION OF DAILY WORK PERIODS.
- BACKFILLING OF CONDUCTOR TRENCHES SHALL BE IN ACCORDANCE WITH THE TRENCH DETAILS SHOWN ON THE DRAWINGS AND SPECIFICATIONS.
- ALL EXCAVATED MATERIALS NOT SUITABLE OR REQUIRED FOR BACKFILL SHALL BE DISPOSED OF BY THE DEVELOPER.
- IT SHALL BE THE RESPONSIBILITY OF THE DEVELOPER TO NOTIFY THE BOARD OF PUBLIC WORKS, TWENTY-FOUR (24) HOURS IN ADVANCE OF ANY CABLE LAYING OR BACKFILL.
- NO CABLE SHALL BE INSTALLED OR TRENCHES BACKFILLED EXCEPT IN THE PRESENCE OF AN INSPECTOR APPOINTED BY THE BOARD OF PUBLIC WORKS
- PIECES OF SCRAP CABLE SHALL NOT BE BURIED IN THE TRENCH AS A MEANS OF DISPOSAL.

608 - SECONDARY CABLE IDENTIFICATION

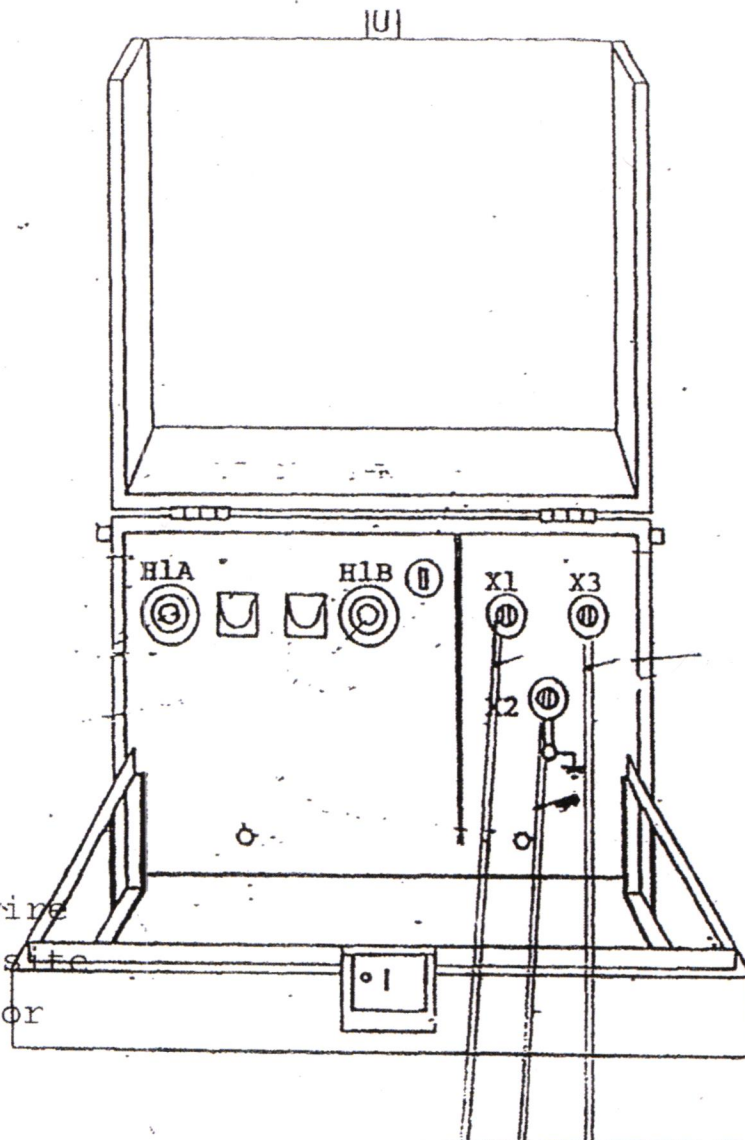

Mark each leg
with colored wire
ties, mark opposite
end w/same color

700 - UNDERGROUND DISTRIBUTION TRANSFORMERS

- 701 TRANSFORMER SPECIFICATIONS, SINGLE PHASE, PRIMARY VOLTAGE 12470 GRDY/7200 60 HZ SECONDARY VOLTAGE 120/240.
- 702 TRANSFORMER SPECIFICATIONS THREE PHASE, PRIMARY VOLTAGE 12470 GRDY/7200 60 HZ SECONDARY VOLTAGE 208/120 OR 480Y/277.
- 704 TRANSFORMER BOX PADS.
 - 704.1 TRANSFORMER BOX PAD AND VAULT.
 - 704.2 TRANSFORMER BOX PAD INSTALLATION GUIDELINES.
- 705 SECTIONALIZING CABINETS 4 WAY.
 - 705.1 SECTIONALIZING CABINET.

701 - TRANSFORMER SPECIFICATIONS SINGLE PHASE PAD MOUNT

SINGLE PHASE PAD MOUNT TRANSFORMER SPECIFICATIONS FOR 25-50-75-100-167 KVA

THE TRANSFORMER WILL BE OIL-FILLED WITH 65 DEGREE RISE ABOVE 30 DEGREE AMBIENT AND SHALL HAVE OIL DRAN AND FILL PLUGS AND A PRESURE RELIEF DEVICE.

DEAD-FRONT, LOOP FEED CONSTRUCTION WIL HIGH VOLTAGE PARKING STANDS.

PAD-MOUNTED, MAXI-PACK.

PRIMARY VOLTAGE 12470 GRDY/7200, 60 HERTZ.

SECONDARY VOLTAGE 120/240, VOLTS SINGLE PHASE THREE WIRE GROUNDED.

BAYONET PRIMARY FUSING DRAW OUT TYPE.

THREADED STUD SECONDARY BUSHINGS.

FINISH TO BE MUNSELL GREEN PAINT.

REA APPROVED DESIGN WITH PENTA-HEAD LOCKING.

UNIVERSAL LOAD BREAK PRIMARY BUSHING WELLS WITH INSERTS 20 AMP.

TRANSFORMER OIL TO BE COOPER ENVIROTEMP FR-3 FLUID OR EQUAL.

NEUTRAL TERMINALS SHALL BE GROUNDED EXTERNALLY THRU BUSHING TO TANK WITH COPPER STRAP.

EXTERNAL SAFETY LABLE AND KVA SIZE, WITH NON-PCB LABEL.

TANK GROUNDING PROVISIONS.

702 - TRANSFORMER SPECIFICATIONS THREE PHASE PAD MOUNT

THREE PHASE PAD MOUNT TRANSFORMER SPECIFICATIONS FOR 75-150-300-500-750-1000 KVA

THE TRANSFORMER WILL BE OIL FILLED WITH 65 DEGREE RISE ABOVE AMBIENT AND SHALL HAVE OIL GAUGE, THERMOMETER, DRAIN VALVE AND SAMPLER, FILL PLUGS AND PRESSURE VACUUM GAUGE PROVISIONS, AND A PRESSURE RELIEF DEVICE.

DEAD FRONT LOOP FEED CONSTRUCTION, WITH HIGH VOLTAGE PARKING STANDS, PAD MOUNTED.

PRIMARY WINDING VOLTAGE 12470 GRDY/7200 VOLTS, 60 HERTZ, TAPS 2 @ 2.5 ABOVE AND BELOW NOMINAL.

SECONDARY VOLTAGE 480/277 OR 208/120 VOLTS.

BAYONET PRIMARY FUSING DRAW OUT TYPE.

LOW VOLTAGE BUSHINGS AND 10 HOLE SECONDARY SPADE TERMINALS WITH NEMA HOLE SPACING.

FINISH TO BE MUNSELL GREEN PAINT.

REA APPROVED DESIGN, WITH PENTA-HEAD LOCKING.

UNIVERSAL LOAD BREAK PRIMARY BUSHING WELLS WITH INSERTS, 200 AMP.

NEUTRAL TERMINALS SHALL BE GROUNDED EXTERNALLY THRU BUSHING TO TANK WITH COPPER STRAP.

ALL STANDARD EQUIPMENT.

EXTERNAL SAFETY LABELS AND KVA SIZE WITH NON-PCB LABELS.

TANK GROUNDING PROVISIONS.

TRANSFORMER OIL TO BE COOPER ENVIROTEMP FR-3 FLUID OR EQUAL.

704 – TRANSFORMER BOX PADS

- MOLDED FIBERGLASS TRANSFORMER BOX PADS SHALL BE PROVIDED FOR EACH UNDERGROUND DISTRIBUTION TRANSFORMER.
- PADS SHALL BE PROPERLY SIZED TO ACCEPT THE TRANSFORMER.
- PADS FOR 3 PHASE TRANSFORMERS SHALL BE FORMED CONCRETE 8" THICK, 4" LARGER ON ALL SIDES THAN THE TRANSFORMER WITH 4" PVC CONDUIT IN PRIMARY AND SECONDARY COMPARTMENTS TO EXTEND THREE (3) FEET BEYOND OUTSIDE OF PAD. CHECK MANUFACTURER'S PAD DIMENSIONS.
- RODS SHALL CONFORM TO THE LATEST REVISION OF ASTMA625.
- TOP OF CONDUITS SHOULD BE 2" ABOVE SURFACE GRADE.
- WHEN PAD IS INSTALLED IN THE TRAFFIC AREA, PROTECTIVE BARRIERS MUST BE INSTALLED.
- TOP OF BARRIERS TO BE 4' ABOVE FINAL GRADE.
- THE MINIMUM ACCEPTABLE STANDARD FOR TRANSFORMER BOX PAD AND VAULT IS PRESENTED IN SECTIONS 704.1 AND 704.2 OF THIS SPECIFICATION.

Nordic Fiberglass Single-Phase Transformer Box Pads

- These heavy duty 1/4" thick box pads are produced of fire-retardant resin and a combination of chopped glass sprayup and hand layup using woven roving glass reinforcement, which contributes greatly to their strength.
- Ribs are built into all sides for greater vertical and side-wall strength.
- The exterior is covered with gel-coat, which contains UV stabilizer in addition to pigments and polyester resin for superior weatherability and resistance to ultraviolet attack.
- Cable entrance holes are optional.
- The AB-1 and AB-2 anchor brackets enable various insert patterns to accommodate more sizes of equipment.

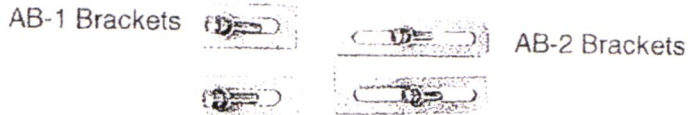
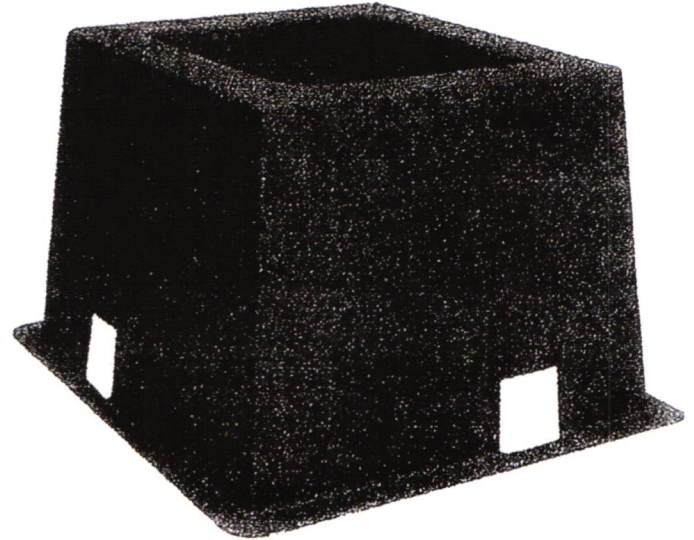

- The ND-28 deferral cabinet is designed for cable feed-through where a transformer will be installed at later date. The GS-37-43-24D and GS-37-43-32C will accommodate the ND-28.

Catalog No.	Outside Dimension	Top Opening
GS-37-43-24A	37" x 43" Top x 24" High	26" x 32"
GS-37-43-24B	37" x 43" Top x 24" High	20" x 20"
GS-37-43-24C	37" x 43" Top x 24" High	12" x 20"
→ GS-37-43-24D	37" x 43" Top x 24" High	22" x 24" ←
GS-37-43-32A	37" x 43" Top x 32" High	26" x 32"
GS-37-43-32B	37" x 43" Top x 32" High	20" x 20"
GS-37-43-32C	37" x 43" Top x 32" High	22" x 24"

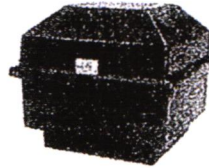

ND-28
GSC-37-43

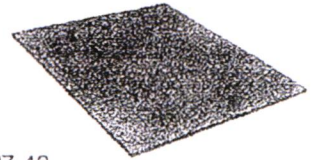

- The GSC-37-43 flat cover has four brass penta-head recesses and comes with four 3/8"x1-1/2" penta-head bolts for securing the cover to the box pad.
- The TDB-1, TDB-2, and TDB-3 brackets are another option for transformer deferral. The GS-37-43-32A and GS-37-43-32C box pads will accommodate these 15kV, 25kV, or 35kV deferral brackets.

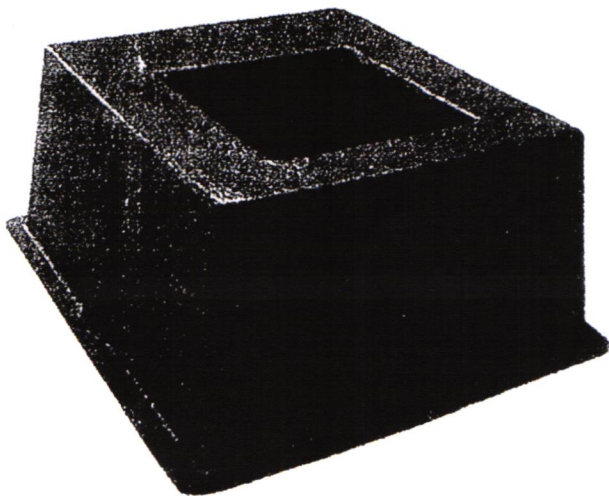

TDB-1



TDB-2

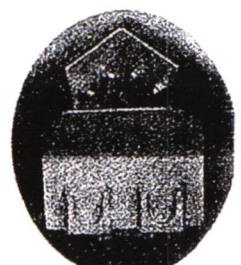

TDB-3

Fabricators of Quality Fiberglass Products
for the Electric Utility Industry

REVISIONS			
REV.	DESCRIPTION	DATE	APPROVED
REL-01		11/8/2005	

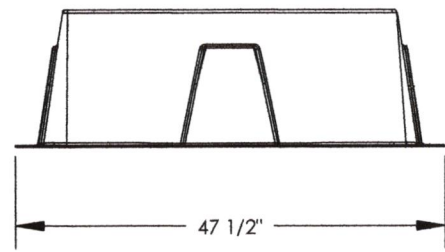
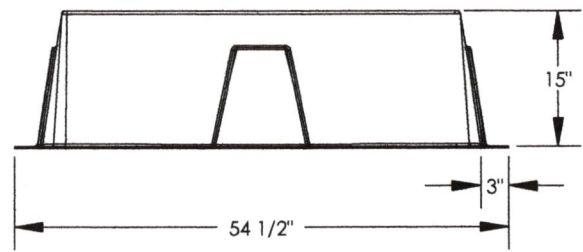
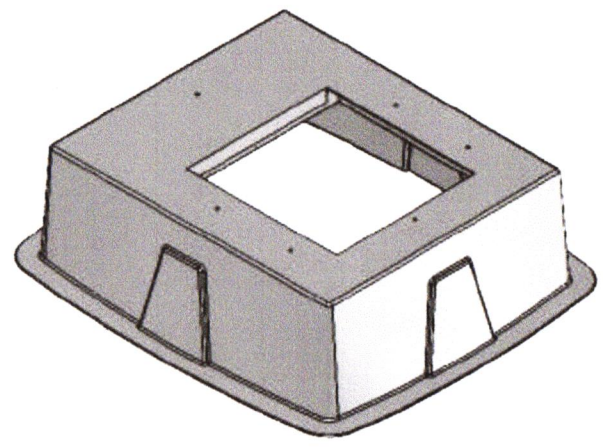
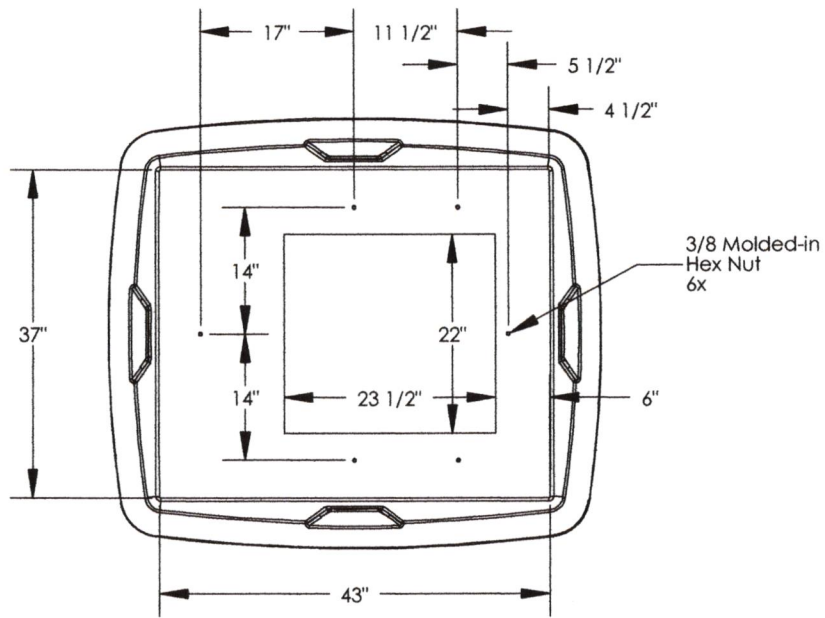

Nordic Fiberglass, Inc.
 21415 US Hwy 75 NW, Warren, MN 56762
 www.nordicfiberglass.com
 218-745-5095 ph. — 218-745-4990 fax
 CBP-37-43-15A-MG-22X24

PROPRIETARY AND CONFIDENTIAL
 THE INFORMATION CONTAINED IN THIS DRAWING IS THE SOLE PROPERTY OF NORDIC FIBERGLASS, INC. ANY REPRODUCTION IN PART OR AS A WHOLE WITHOUT THE WRITTEN PERMISSION OF NORDIC FIBERGLASS, INC. IS PROHIBITED.

Customer Name: N/A		MATERIAL		SIZE	ITEM ID:	REV.
DIMENSIONS ARE IN INCHES				A	00150.00	REL-01+
TOLERANCES: ANGLES ± 1°						
FRACTIONAL ± 1/2		NAME	DATE			
ONE PLACE DECIMAL ±.060		P.L.W.	11/07/05			
TWO PLACE DECIMAL ±.030		CHECKED		SCALE: 1:20	SHEET 1 OF 1	
THREE PLACE DECIMAL ±.015						

INSTALLATION GUIDELINES

Trenching and Digging

Figs. 1 and 2 show the most common relationships between the cable trench and the box pad opening. Since a firm base for the box pad is very important, the offset relationship (Fig. 1) is preferable. Any trenching under the pad must be thoroughly filled in and tamped.

Some utilities lay-in the primary cables before digging the box pad opening. Others install the box pad and the cables, and then install the fiberglass cover until they are ready to install the transformer.

Box-Pad Opening Size (Fig.3)

The opening should be at least 6'X6'X33" deep.

FIG 1

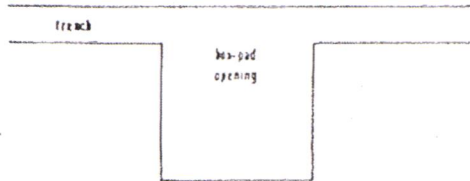
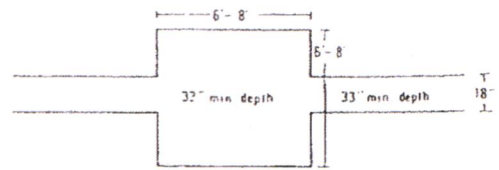

FIG 2



FIG 3



BOX PAD OPENING DIMENSION

Base Preparation (Figs. 4 & 5)

This is extremely important. The bottom flange must rest on a firm foundation, and we recommend that a 3" base be prepared and thoroughly tamped. After the box pad has been placed in position and levelled, 3" of soil should be placed on the flange to keep the box pad in place. Some installers place 3" of sand inside the box pad to hold it in place.

Backfilling

Some utilities delay back-filling so that their linesmen can stand in the opening and work on the transformer at waist-height, rather than working on their hands and knees. They use the box pad as a work bench.

When backfilling, make sure that no large boulders are resting against the sides of the box, since they could produce high pressure points.

Sand is not a good back filling material since it provides very little resistance to surface loads.

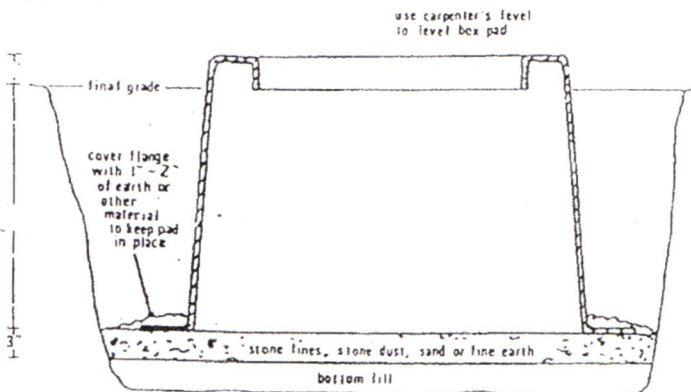

INSTALLATION DETAILS

FIG 4

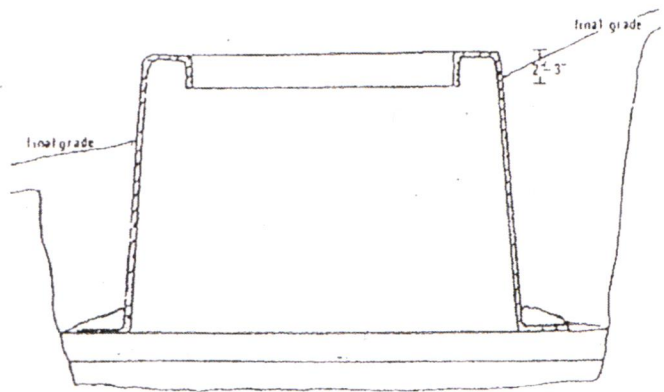

MEASURING DEPTH ON SLOPING LAND

FIG 5

705 – SECTIONALIZING CABINETTS – 4 WAY

WHERE USED, THE MINIMUM ACCEPTABLE STANDARD FOR SECTIONALIZING CABINETS SHALL BE NORDIC ND-360, SUPPLIED WITH ALL HARDWARE FOR 4 WAY SECTIONALIZING PER SECTION 705.1 OF THIS SPECIFICATION.

705.1 Sectionalizing Cabinet



NORDIC FIBERGLASS, INC.

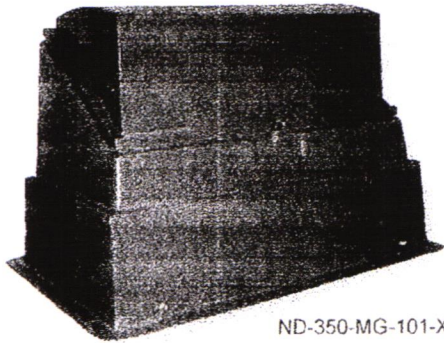

ND-350-MG-101-X-X

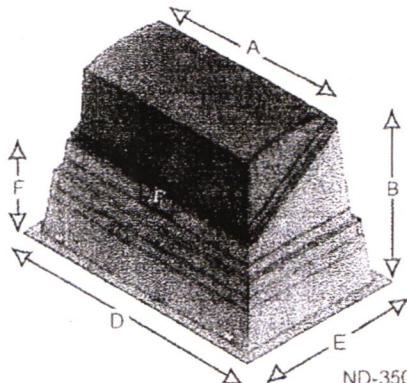

ND-350-MG-101-X-X

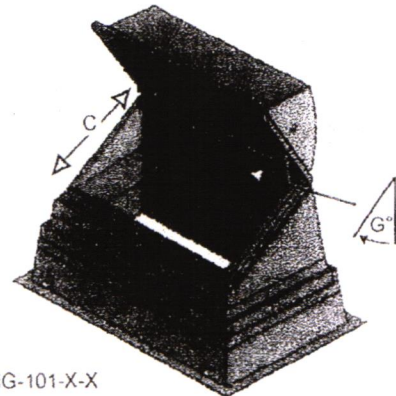

Material Specifications: ND three phase hinged cabinets are produced of fire retardant resin and a combination of chopped glass spray-up and hand-lay up using woven roving glass reinforcement. The exterior is covered with gel-coat, which contains UV stabilizer for superior weather-ability. All hardware is stainless steel.

ND Roto-Cab Sectionalizing Cabinets	A Top Width	B Cabinet Height	C Top-Operating Depth	D Base Width	E Base Depth	F Max. Burial Depth	G Angle	Units per Pallet
ND-250-MG-101-X-X	53.5"	34.5"	23"	67"	37"	Pad Mount	5°	3
ND-330-MG-101-X-X	53.5"	36"	19"	75"	45.5"	10"	20°	3
ND-350-MG-101-X-X	53.5"	48"	22.5"	77.5"	47"	16"	5°	2
ND-360-MG-101-X-X	53.5"	54"	23"	77.5"	47"	27"	5°	2
ND-430-MG-101-X-X	68.5"	53"	25.5"	93"	52.5"	10"	20°	2
ND-450-MG-101-X-X	68.5"	64.5"	29"	96"	54.5"	23.5"	5°	2

Ordering Example: ND-350-MG-101-4152-B3A

Style	Dimensions	Color	Mounting Plate	Load or Dead Break Junction Accommodations	Ground System	Special Part Number
ND	350	MG	101	4152	B3A	Suffix
N-Nordic D-Design	200=Pad Mount 300-400=Direct Burial	MG-Munsell Green WG-Willow Green DT-Desert Tan GR-Mist Gray Special Colors upon request	101-Hot-Dipped Galvanized Steel X-No Mounting Plate Optional Mounting Plate: S101, Stainless Steel Mounting Plate (Below Parking) 10135=Hot-Dipped Galv. for ND-430 & 450 S10135=SST for ND-430 & 450	X=No load or deabreak junctions 4 Interfaces: 2=2pt, 3=3pt, 4=4pt 15 Kilo-Volts: 15=15kV, 25=25kV, 35=35kV 2 Amps: 2=200A, 6=600A Accommodates 1, 2-4pt. Junction with U-strap from the following manufacturers: H=Hubbell, E=Elastomold, C=Cooper 200 Amp Deabreak Junction: kV H E C 15 Yes Yes Yes 25 Yes Yes Yes 35 N-A Yes *Yes 600 Amp Deabreak Junction: 15-25kV Yes Yes Yes 35kV N-A Yes *Yes	B3A= 3/8" solid conductor W3A=#2 bare strand wire X=No Ground System ND-250,330,350,360, have either B3A or W3A ground systems ND-430, 450: B3B= 3/8" solid conductor W3B=#2 bare strand wire X=No Ground System	Suffix is for special custom products CAS-Cabinet Anchor System (for cement pad mount applications) ND-250 comes with a cabinet anchoring system If blank, not a special

*Pertains to ND-430-450 with (S)10135 mounting plates will accommodate 200A Taps and all Cooper Junctions. SS-MP-101 will not accommodate Cooper 35kV/200A junctions and no Cooper 35kV/600A Deabreak junctions.

Fabricators of Quality Fiberglass Products for the Electric Utility Industry
21415 US Highway 75 NW · P.O. Box 27 · Warren · Minnesota · 56762
Ph: (218) 745-5095 Fx: (218) 745-4990 www.nordicfiberglass.com



800 – CONDUIT/U-GUARD

801 CONDUIT SPECIFICATION

801 – CONDUIT SPECIFICATION

ALL CONDUIT INCLUDING SPARE CONDUIT SHALL BE SCHEDULE 40 PVC CONDUIT SUITABLE FOR DIRECT BURIAL.

CONDUIT SHALL BE SIZED AND INSTALLED IN ACCORDANCE WITH ARTICLE 347 OF THE NATIONAL ELECTRIC CODE.

ALL CONDUIT SHALL BE CARLON PLUS 40 OR APPROVED EQUAL SCHEDULE 40 PVC AND SHALL CONFORM TO NEMA SPECS, TC-2 CONDUIT, TC-3 FITTINGS, UL-514, UL651.

ALL EXPOSED ENDS OF CONDUIT SHALL BE PLUGGED DURING CONSTRUCTION TO PREVENT THE ENTRANCE OF FOREIGN MATERIAL AND MOISTURE.

BURRS, SHARP EDGES AND PROJECTIONS SHALL BE REMOVED.

OPEN ENDS OF CONDUIT SHALL HAVE BUSINGS INSTALLED TO PROTECT CABLES.

RISER CONDUITS SHALL EXTEND AT LEAST TWO (2) FEET ABOVE GRADE.

ALL SPARE CONDUIT SHALL BE INSTALLED NEXT TO SERVICE CONDUIT.

ENDS OF SPARE CONDUIT SHALL REMAIN SEALED WITH GLUED PVC CAPS TO EXCLUDE THE ENTRANCE OF FOREIGN MATERIAL AND MOISTURE.

1000 – STREET LIGHTING

- 1001 SUBDIVISION STREET ILLUMINATION DESIGN REQUIREMENTS
- 1001.1 POST TOP LUMINAIRE TRADITIONAL DESIGN
- 1001.2 POST TOP AMERICAN REVOLUTION LUMINAIRE
- 1001.3 LUMINAIRE SUPPORT STRUCTURE
- 1001.4 LUMINAIRE SUPPORT STRUCTURE
- 1001.5 LUMINAIRE SUPPORT STRUCTURE
- 1002 STREET LIGHTING CABLE SPECIFICATION
- 1002.1 STREET LIGHTING CABLE CHARACTERISTICS
- 1003 SECONDARY AND STREET LIGHTING CABLE ACCEPTANCE TEST

1001 - SUBDIVISION STREET ILLUMINATION DESIGN
REQUIREMENTS

SUBDIVISION STREET ILLUMINATION SHALL BE IN COMPLIANCE WITH THE APPLICATION DESIGN STANDARDS OF PART IV. LIGHTING APPLICATIONS. CHAPTER 24 - ROADWAY LIGHTING OF THE LIGHTING HANDBOOK, 8TH EDITION OF THE ILLUMINATING ENGINEERING SOCIETY OF NORTH AMERICA. APPLICABLE AREA CLASSIFICATIONS INCLUDE LOCAL ROADWAYS AND RESIDENTIAL.

The minimum Acceptable Standard Luminaire For Design Application is The Cooper Lighting LXF PA1 40 740 U T3 A BK 10K PR7 Sodium 120 Volt. Top Mounted Photo Receptacle.
The Standard Distribution Pattern For This Luminaire is IES Type III.

VALUES FOR ROADWAY AVERAGE MAINTAINED LUMINANCE SHALL CONFORM TO THOSE DATA OF FIGURE 24-8 OF CHAPTER 24, IES HANDBOOK, PART IV.

THE VALUES FOR LUMINANCE UNIFORMITY OF THE ROADWAY LIGHTING DESIGN SHALL COMPLY WITH THE DATA OF FIGURE 24-8. (I.E., LUMINANCE AVERAGE LEVEL TO MINIMUM LEVEL RATIO SHALL NOT EXCEED 6 TO 1.)

LUMINAIRE SUPPORT STRUCTURES SHALL COMPLY WITH DESIGN STANDARDS OF AASHTO - STANDARD SPECIFICATIONS FOR STRUCTURAL SUPPORT HIGHWAY SIGNS, LUMINAIRES, AND TRAFFIC SIGNALS 1985.

1001.1 Post Top Luminaire Design

Notes

- 1 Photo Control To Be Mounted Per Manufacturers Spec's
- 2 All Hinges Set Screws and Screws to be Coated With Inhibiting Compound
- 3 Back Fill and Tamp Hole
- 4 Line connection to Nearest Point, Transformer or Pedestal
- 5 In Line Fuse

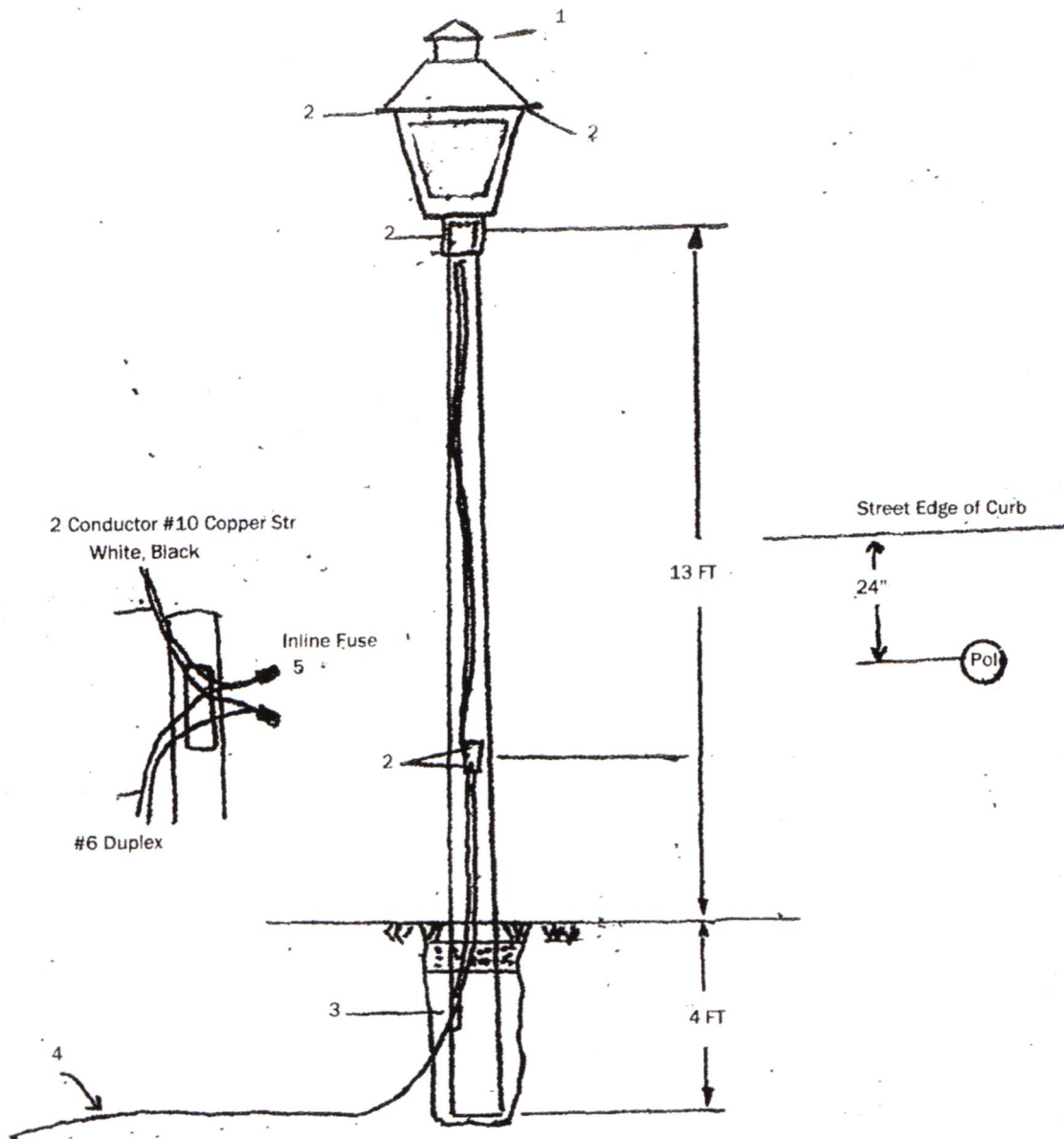

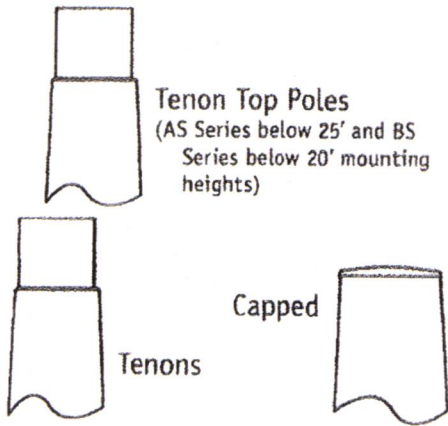

TENONS: 2³/₈", 3", 4" OD, if pole dimensions permit. Tenons are A356-T6 aluminum or hot-dipped galvanized steel, and are available in all standard sizes; for other optional tenons contact Shakespeare. Post top fixtures, flood lights, or brackets mount with ease.

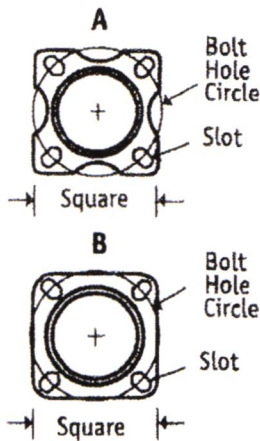

Anchor Base Dimensions

Bolt Hole Circle	Drawing	Square	Slot
8"	A	7.75"	1 ³ / ₁₆ " x 1 ⁵ / ₁₆ "
8 ¹ / ₂ "	A	8.125"	1 ³ / ₁₆ " x 1 ⁵ / ₁₆ "
9 ¹ / ₂ "	A	8.8"	1 ³ / ₁₆ " x 1 ⁵ / ₁₆ "
11 ¹ / ₂ "	B	11"	1 ³ / ₄ " x 1 ³ / ₄ "
14"	B	12.9"	1 ¹ / ₂ " x 2"
14 ¹ / ₂ "	B	13.3"	1 ¹ / ₂ " x 2"
15"	B	13.5"	1 ¹ / ₂ " x 2"
15 ¹ / ₂ "	B	14"	1 ¹ / ₂ " x 2"

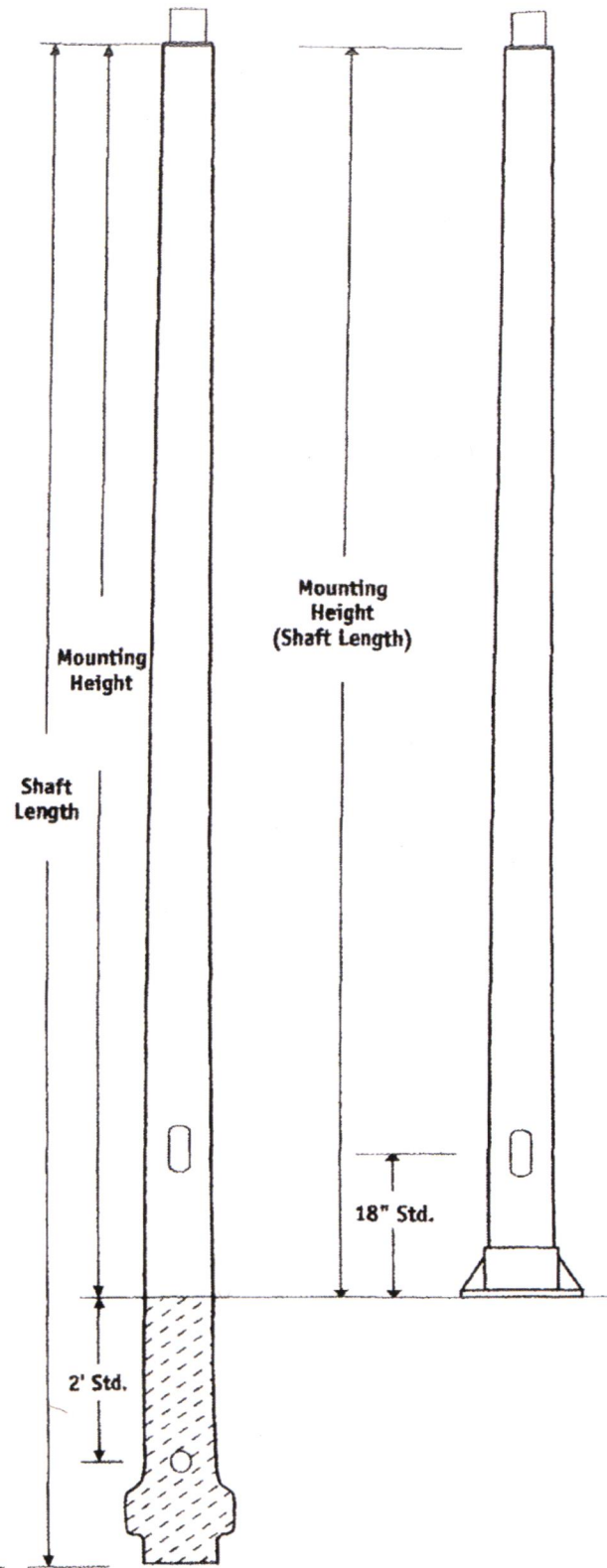

ANCHOR BASE: Cast A356-T6 aluminum, polyurethane coated to match pole color.

Hot dipped galvanized steel anchor bolts complete with nuts (2) and washers (2) are supplied standard (5/8" x 21" x 3", 1" x 30" x 4", or 1¹/₄" x 36" x 6" depending on the pole specified).

SAMPLE NUMBER: **LXF-PA1-20-740-U-T2U-CL-BK-10MSP-PR7**

Product Family ¹	Configuration	Wattage Bucket	Color Temperature	Voltage	Distribution	Lens	Finish
LXF=Lexington LXT=Lexington w/ Traditional Top BAA-LXF=Lexington Buy American Act Compliant ¹⁰ TAA-LXF=Lexington Trade Agreements Act Compliant ¹⁰ BAA-LXT=Lexington w/ Traditional Top Buy American Act Compliant ¹⁰ TAA-LXT=Lexington w/ Traditional Top Trade Agreements Act Compliant ¹⁰	PA1=Direct Mount Rectangle (24 LED)	20=20W ² 30=30W 40=40W 50=50W 60=60W 70=70W 80=80W 90=90W 100=100W	740=70CRI, 4000K 727=70CRI, 2700K ⁵ 827=80CRI, 2700K ⁵ 730=70CRI, 3000K ⁵ 750=70CRI, 5000K ⁵ AMB=Amber 590nm	U=Universal (120-277V) 2=120V ² 8=480V ⁴ 9=347V	T2U=Type II Urban T3=Type III T4W=Type IV Wide 5WQ=Type V Square Wide SL3=Type III w/ Spill Control	[Blank]=Open (No Lens) A=Refractive Lens Panels CL=Clear Lens Panel FL=Frosted Lens TL=Textured Lens Panel	BK=Black AP=Grey BZ=Bronze WH=White
Options (Add as Suffix)			Controls		Accessories (Order Separately) ¹¹		
10K=Series 10kV UL 1449 Surge Protective Device 20K=Series 20kV UL 1449 Surge Protective Device 20KI=Series 20kV UL 1449 Surge Protective Device with light indicator 20MSP=Parallel 20kV MOV Surge Protective Device 10MSP=10kV MOV Surge Protection Device HA=50°C High Ambient Temperature ⁸ S=Snap Latches for Tool-less Light Replacement J=Factory Installed Ladder Rest HSS=House Side Shield ⁷ TC=Tall Cupola ⁹ PSC=Photocontrol Shorting Cap NPC=NEMA Photocontrol - Multi-Tap LLPC=Longlife Photocontrol Included			SLTD=DALI ² PR=NEMA Photocontrol Receptacle ⁶ PR7=NEMA 7-PIN Twistlock Photocontrol Receptacle		TA1BK=Decorative Ladder Rest for Field Installation (Black) OA/RA1013=Photocontrol Shorting Cap OA/RA1014=NEMA Photocontrol - 120V OA/RA1016=NEMA Photocontrol - Multi-Tap OA/RA1027=NEMA Photocontrol - 480V OA/RA1201=NEMA Photocontrol - 347V OA1223=10kV Surge Module Replacement HS-LX-24=Field Installed House Side Shield ⁷ VGS-ARCH=Short Vertical Drop Shield VGL-ARCH=Long Vertical Drop Shield		
<p>NOTES:</p> <p>1. Customer is responsible for engineering analysis to confirm pole and fixture compatibility for all applications. Refer to our white paper WP513001EN for additional support information.</p> <p>2. PA1-20 only available in 120V only.</p> <p>3. Only available in universal voltage. Consult your lighting representative at Cooper Lighting Solutions if custom programming is required. Not available with PA1-90, PA1-100. Consult your lighting representative at Cooper Lighting Solutions if greater than PA1-80 (83W) is needed.</p> <p>4. Only for use with 480V Wye systems. Per NEC, not for use with ungrounded systems, impedance grounded systems or corner grounded systems (commonly known as Three Phase Three Wire Delta, Three Phase High Leg Delta and Three Phase Corner Grounded Delta systems).</p> <p>5. Use dedicated IES files when performing layouts. These files are published on the Lexington product page on the website.</p> <p>6. If "PR" selected, dimming functionality not available, leads will be capped.</p> <p>7. HSS not available with 5WQ distribution.</p> <p>8. HA not available with PA1-100 if paired with HSS option.</p> <p>9. Use tall cupola to accommodate network control solutions requiring the 7-pin receptacle.</p> <p>10. Only product configurations with these designated prefixes are built to be compliant with the Buy American Act of 1933 (BAA) or Trade Agreements Act of 1979 (TAA), respectively. Please refer to website for more information. Components shipped separately may be separately analyzed under domestic preference requirements.</p> <p>11. Accessories sold separately will be separately analyzed under domestic preference requirements. Consult factory for further information.</p>							

- Hinged die-cast aluminum top with cupola cover
- Captive retaining screw
- Die-cast aluminum base housing
- Other finish colors available; Consult your Streetworks representative
- 1" ANSI wattage/source label
- Choice of five patented, high efficiency AccuLED Optics™ technology manufactured from injection-molded acrylic
- Optics are precisely designed to shape the light output, maximizing efficiency and application spacing; AccuLED Optics technology creates consistent distributions with the scalability to meet customized application requirements
- Offered standard in various CCTs and minimum 70 CRI
- For the ultimate level of spill light control, an optional house-side shield accessory can be field or factory installed
- Optics are IP66 enclosure rated
- Offered open sided as a standard with four lens options
- IDA Certified for 3000K CCT and warmer and Open version (no lens) only
- LED drivers mount to die-cast aluminum back housing for optimal heat sinking, operation efficacy, and prolonged life
- Standard drivers feature electronic universal voltage (120-277V, 50/60Hz), 347V 60Hz or 480V 60Hz operation, greater than 0.9 power factor, less than 20% harmonic distortion, and is suitable for operation in -40°C to 40°C ambient environments.
- 10 kV/10 kA common and differential mode and 10 kV MOV surge protection available
- Self-aligning pole-top fitter fits 2-3/8" and 3" O.D. tenons
- Square headed 1-1/4" polymer coated mounting bolts
- Cast components finished in a Super durable TGIC polyester powder coat paint, 2.5 mil nominal thickness for superior protection against fade and wear
- Optional colors include bronze, grey and white; RAL and custom color matches available
- Approximate Net Weight: 25 lbs. (11 kgs.)
- Effective Projected Area: 1.7 (Sq. Ft.)
- Standard five-year warranty
- Optional ten-year warranty, please see your Cooper Lighting Solutions Streetworks sales representative for more information

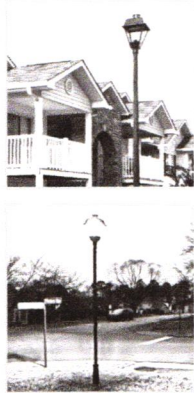

LXF / LXT Lexington

Decorative Post Top Luminaire

Product Features



Light ARchitect™

- Ordering Information [page 2](#)
- Product Specifications [page 2](#)
- Energy and Performance Data [page 3](#)



- Replaces up to 400W equivalent HID
- Asymmetric & Symmetric distributions
- 0-10V dimming driver standard
- UL 1449/MOV surge protection available
- 3G vibration rated

LXF

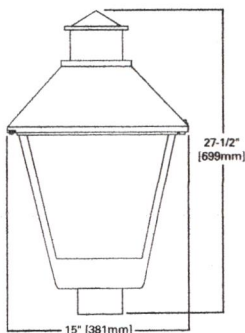

LXT

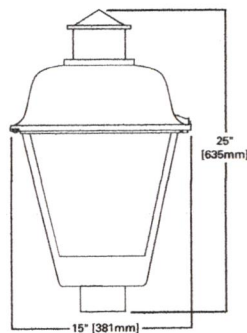

LXF - Tall Cupola

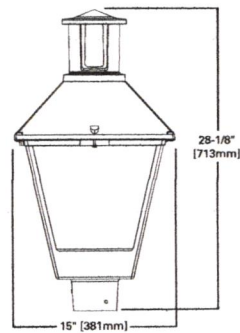

LXT - Tall Cupola

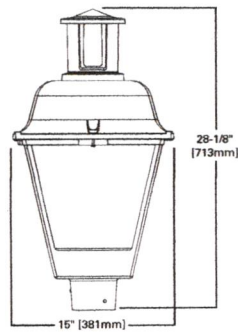

NOTES:

1. IDA Certified for 3000K CCT and warmer and Open version (no lens) only.

1001.4

Tenon Top Composite Tuff-Poles[™]

AS and BS Series, Anchor Base and Direct Burial Base
Round Tapered

COMPOSITE TUFF-POLE

Nominal Mounting Height (ft.)	Shaft Length (ft.)	Pole Weight (lbs.)	POLE DIAMETER		Standard Handhole Location from Base (in.)	SUGGESTED MAXIMUM TOTAL LOADING					Bolt Hole Circle (in.)	BASIC CATALOG NUMBER	Comment
			Shaft Top (in.)	Shaft Base (in.)		Total Weight (lbs.)	80 MPH EPA* (sq. ft.)	90 MPH EPA* (sq. ft.)	100 MPH EPA* (sq. ft.)	120 MPH EPA* (sq. ft.)			
Anchor Base, Series AS, Tenon Top													
10**	10	22	2.9	4.6	18	150	16.3	12.5	9.9	6.7	8	AS10	Tenon Top only
12**	12	25	2.9	4.9	18	150	13.6	10.3	8.1	5.3	8	AS12	Tenon Top only
14**	14	28	2.9	5.3	18	150	9.8	7.2	5.6	3.6	8	AS14	Tenon Top only
16**	16	30	2.9	5.5	18	100	6.8	4.9	3.7	2.2	8.5	AS16	Tenon Top only
18**	18	34	2.9	5.8	18	100	6.7	4.9	3.8	2.4	8.5	AS18	Tenon Top only
20**	20	44	2.9	6.1	18	100	5.7	4.0	3.1	1.8	8.5	AS20	Tenon Top only
25**	25	52	2.9	6.8	18	100	4.0	2.9	2.1	0.9	9.5	AS25	Tenon Top only

**Not available Capped - do not use AS Series below 25' mounting height for side mount applications, or with tenon mounted arms or for multiple fixture applications - Use A0 Series, instead.

Nominal Mounting Height (ft.)	Shaft Length (ft.)	Pole Weight (lbs.)	POLE DIAMETER		Standard Handhole Location from Base (in.)	SUGGESTED MAXIMUM TOTAL LOADING					Suggested Burial Depth (ft.)	BASIC CATALOG NUMBER	Comment
			Shaft Top (in.)	Shaft Base (in.)		Total Weight (lbs.)	80 MPH EPA* (sq. ft.)	90 MPH EPA* (sq. ft.)	100 MPH EPA* (sq. ft.)	120 MPH EPA* (sq. ft.)			
Direct Burial Base, Series BS, Tenon Top													
10**	13	23	2.9	5.0	54	150	16.3	12.5	9.9	6.7	3	BS13	Not available Capped
12**	15	25	2.9	5.3	54	150	10.7	7.9	6.1	4.1	3	BS15	Not available Capped
13**	17	27	2.9	5.6	66	150	10.2	7.6	5.9	3.9	4	BS17	Not available Capped
14**	18	29	2.9	5.7	66	150	9.7	7.1	5.6	3.7	4	BS18	Not available Capped
16**	20	38	2.9	6.1	66	100	7.3	5.3	4.2	2.7	4	BS20	Not available Capped
20**	24	44	2.9	6.6	66	100	6.1	4.6	3.5	2.2	4	BS24	Not available Capped

**Not available Capped - do not use BS Series below 20' mounting height for side mount applications, or with tenon mounted arms or for multiple fixture applications - Use B0 Series, instead.

For capped poles, and poles suitable for side mount or arm mounted fixtures, see Round Tapered Poles. For poles with arms, see Mast Arm Poles.

■ Standard handhole: 2½" x 5" oval. All handhole covers are polyurethane coated to match pole color.
*All EPA recommendations are based on poles with handholes, and include a 30% gust factor for all wind speeds, including 120 mph.

A complete Shakespeare Composite Structures Composite Tuff-Pole® Catalog Number includes all of the information detailed below, in order from left to right, including the dash. The letters and numbers to the left of the dash are the Basic Catalog Number found in the listings of the poles. Poles with mast arms include two digits to the right of the dash. The remainder of the Catalog Number details the options which you can specify in the order listed to define accessories, handholes, colors, etc. Please use the

standard specification for these options whenever possible.

You can assemble your own catalog numbers, or call for assistance. Most of the available options are listed in the template. Call for information on all other options.

How to use this manual

To decide which Tuff-Pole® you need, first consider your application: Anchor Base or Direct Burial. Shakespeare Composite Structures recommends Direct Burial style

poles for cost efficiency and ease of installation, if your application permits. Next choose round or square, standard or Breakaway, hinge or stub styles, and the method of luminaire attachment and wiring access. Then, using your required mounting height, wind speed, and the total EPA and weight of all intended attachments, select a pole with loading ratings that meet your needs.

If you need help choosing or specifying, our experienced staff will be glad to help. Just call.

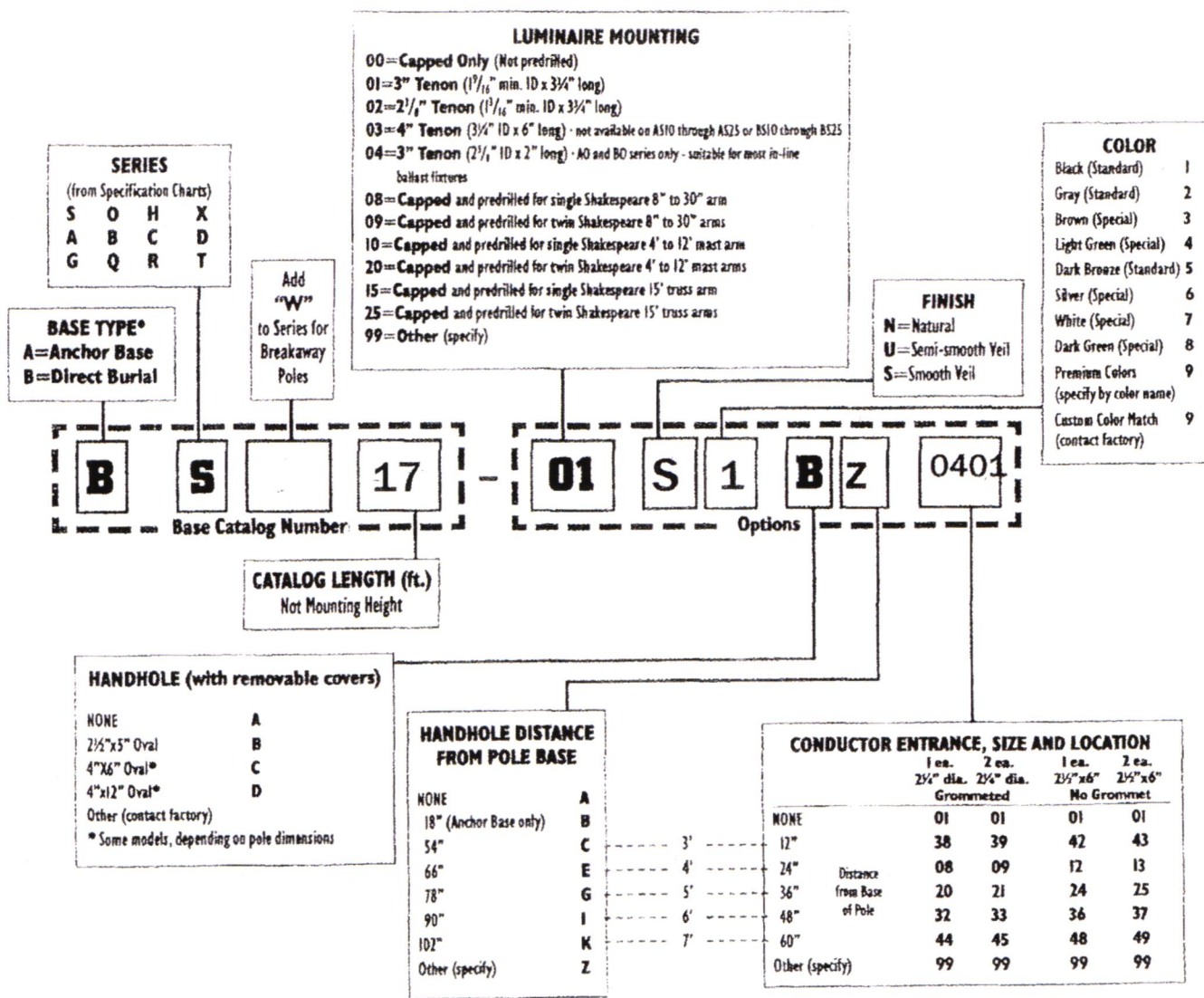

*Order logic and specifications for Tuff-Stub base poles are detailed in Shakespeare Composite Structures publication LSP-I. Order logic and specifications for Tuff-Hinge hinged base poles are detailed in Shakespeare publication LHP-I. For SportsLighting Tuff-Poles up to 125' mounting height, ask for SportsLighting brochure.

1002 – STREET LIGHTING CABLE SPECIFICATION

ALL STREET LIGHTING CABLE INTENDED FOR UNDERGROUND DISTRIBUTION IN CONDUIT OR DIRECT BURIAL SHALL HAVE THE FOLLOWING MINIMUM ACCEPTABLE CHARACTERISTICS AND PERFORMANCE PER PRODUCT DATA PRESENTED IN SECTION 1002.1 OF THIS SPECIFICATION.

- DIRECT BURIAL
- 600 VOLT, XLP INSULATION, CROSSLINKED POLYETHYLENE DUPLEX CABLE CONFIGURATION.
- PHASE CONDUCTORS: THE CONDUCTOR SIZE SHALL BE MINIMUM #6 AWG STRANDED ALUMINIUM ALLOY TYPE 1350.
- NEUTRAL CONDUCTORS: STRANDED ALUMINUM, FULL RATED, MINIMUM NO. 6.
- CONDUCTOR SIZES FOR APPLICATIONS ABOVE THE MINIMUM RATING FOR #6 CABLE SHALL BE SIZED PER NEC ARTICLE 310.
- INSULATION: THE PHASE CONDUCTOR AND THE NEUTRAL CONDUCTOR SHALL HAVE AN INSULATION THICKNESS OF NOT LESS THAN 60 MILS.
- NEUTRAL CONDUCTOR: THE NEUTRAL CONDUCTOR INSULATION SHALL BE READILY IDENTIFIABLE WITH AN EXTRUDED YELLOW STRIPE.
- SPECIFICATIONS: UL NO. 44, UL NO. 854, ICEA-S-66-524/NEMA WC7.
- MANUFACTURER: SOUTHWIRE CLAFLIN/HI OR EQUAL.

Secondary UD HI-SCORE

Aluminum Conductors. Ruggedized XLP Insulation.
Provides Superior Mechanical Protection.

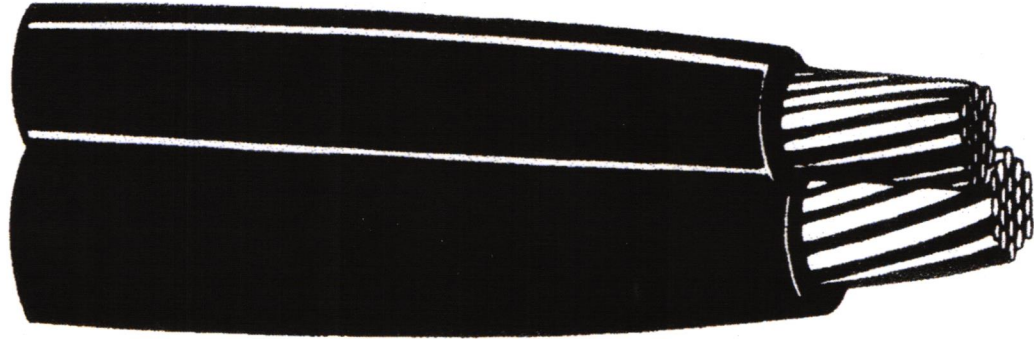

APPLICATIONS

Used for secondary distribution and underground service at 600 volts or less, either direct burial or in ducts. Especially suited for applications requiring superior resistance to mechanical damage. Rated 90°C continuous operation, 130°C emergency overload and short circuit 250°C.

SPECIFICATIONS

HI-SCORE duplex 600 volt secondary UD cable meets or exceeds the following applicable ASTM specifications:

- B-231 Aluminum 1350 Conductors, Concentric-Lay-Stranded.
- B-609 Aluminum 1350 Round Wire, Annealed and Intermediate Tempers, for Electrical Purposes.
- B-786 19 Wire Combination Unilay-Stranded Aluminum Conductors for Subsequent Insulation.
- B-901 Compressed Round Stranded Aluminum Conductors Using Single Input Wire.

HI-SCORE duplex 600 volt secondary UD cable insulation meets or exceeds all grade and type requirements of ICEA S-81-570 and UL Standard 854 for Type USE-2.

CONSTRUCTION

Conductors are stranded, compressed 1350-H16/H26 aluminum, insulated with a cross-linked polyethylene meeting the requirements of ANSI/ICEA S-81-570. Neutrals are triple yellow extruded stripe. Cables with "YES" neutrals have sequential footage markers. Conductors are durably surface printed for identification.

Spliced Cables Will Not be Accepted

1002.1

1003 – SECONDARY AND STREET LIGHTING

CABLE ACCEPTANCE TEST

ACCEPTANCE TESTING OF ANY CABLE SHALL BE PERFORMED WITH ALL CABLE TERMINATIONS IN PLACE BUT DISCONNECTED FROM THE SYSTEM.

CABLE TESTING SHALL BE PERFORMED BY A CERTIFIED TESTING AGENCY APPROVED BY THE CITY OF LEWES, BOARD OF PUBLIC WORKS.

CABLES RATED 600 VOLTS OR LESS SHALL NOT BE HIGH POTENTIAL TESTED; BUT SHALL BE ACCEPTANCE TESTED AT 1000 VOLTS DC FOR ONE (1) MINUTE.

WARNING:

THE APPLICATION OF SERVICE VOLTAGE OR TEST VOLTAGE TO A CABLE MAY CAUSE A VOLTAGE RECOVERY OF SUFFICIENT MAGNITUDE TO CREATE A HAZARD. EXTREME CARE MUST BE TAKEN TO OPEPERLY AND COMPLETELY DISCHARGE THE CABLE AFTER COMPLETION OF TESTING.

1200 – PROTECTIVE DEVICES AND SUPPORTING HARDWARE

- 1201 15 KV SINGLE PHASE FUSED CUTOUT
- 1201.1 FUSED CUTOUT SPECIFICATIONS
- 1202 3 PHASE EQUIPMENT MOUNTING BRACKET
- 1203 9 KV DISTRIBUTION ARRESTERS

1201 - 15 KV SINGLE PHASE FUSED CUTOUT

EACH PRIMARY CABLE SHALL HAVE A 15 KV LOAD-BREAK FUSED CUTOUT INSTALLED AT THE TOP OF THE PRIMARY RISER POLE.

CUTOUTS SHALL BE DISTRIBUTION CLASS, CROSSARM MOUNTED WITH ARC SUPPRESSOR.

CUTOUTS SHALL BE LOCATED THAT THEY MAY BE READILY AND SAFELY OPERATED AND RE-FUSED; AND SO THAT THE EXHAUST OF THE FUSE SHALL NOT ENDANGER PERSONNEL OR EQUIPMENT.

CUTOUTS SHALL HAVE PERMANENT, LEGIBLE IDENTIFICATION SHOWING MANUFACTURERS TYPE, CONTINUOUS CURRENT RATING, MAXIMUM VOLTAGE RATING AND INTERRUPTING RATING.

CUTOUTS SHALL BE 100 AMPERE CONTINUOUS RATED WITH T-LINK FUSES OF APPROPRIATE RATING FOR THE SYSTEM.

THE ACCEPTABLE MANUFACTURER FOR CUTOUTS SHALL BE ABB TYPE LBU II OVERHEAD POLE TOP STYLE, 15 KV, 110 BIL, 100 AMPERE CATALOG NO. 279c789AII, AS PRESENTED IN SECTIONS 1201.1, 1201.2 OF THIS SPECIFICATION.

FUSE RATINGS SHALL BE SELECTED PER ARTICLE 230 OF THE NATIONAL ELECTRIC CODE.

LBU-II

Outdoor loadbreak cutout



Product features

- 7.8/15 kV, 15 kV, 15/27 kV, 20/34.5 kV, and 27 kV
- 110, 125, 150, and 170 kV BIL
- 100 A, 200 A fused
- 300 A disconnect blade
- Porcelain, polymer concrete, or silicone insulators available
- Cutout/arrester combo

Description

The LBU-II cutout performs as an outdoor loadbreak switch, as well as a fused cutout for distribution systems. Loadbreak interruption is accomplished by means of a self-contained loadbreak arc chute which confines the arc and provides a deionizing action.

Conventional operation loadbreak is accomplished by normal opening of the cutout by a hookstick. There are no parts to replace and the loadbreak feature lasts the life of the cutout. The self-contained loadbreak concept enables the line worker to interrupt load current with a simple hook-stick operation. Silicone or polymer concrete insulators and cutout/arrester combinations are available on certain models.

The LBU-II can successfully switch currents as high as 300 A at 15 kV and 50 A at 27 kV. It has fault-

LBU-II loadbreak cutouts are used on overhead distribution systems to provide overcurrent protection, visible indication of fuse operation, and outdoor loadbreak switching.

interrupting (not loadbreak) capacities as high as 20,000 A RMS asymmetrical.

Capacitor banks

The LBU-II provides over-current protection for capacitor banks and gives visible indication that the equipment is de-energized. It also provides a convenient and inexpensive switch capable of interrupting capacitor currents.

Transformer bank switching

The LBU-II can be used for switching the magnetizing currents of both single-phase and three-phase transformer banks.

Sectionalizing

The LBU-II provides a convenient method of sectionalizing single and three-phase, loop, or lateral lines during maintenance or under contingency conditions.

Riser pole

The LBU-II provides a way to switch the capacitive currents associated with the underground feeder cables at the riser pole.

Ordering instructions for LBU-II cutouts

7.8/15 kV and 15 kV LBU-II

Digit	Description	Code	Definition
1	LBU-II cutout	Y	7.8/15 kV and 15 kV
2	Insulator BIL	I	110 kV BIL
		N	Porcelain
		J	Silicone
3	Fuse supports	Z	Polymer concrete
		C	Clamshell
		E	Eyebolt
		N	None
4	Terminal connectors	N	No bracket
		A	NEMA A
		B	NEMA B
		L	Extended
5	Bracket	C	Universal Combo
6	Special options	N	None
		AM11	100 A, 12 kAIC, solid cap (rated 7.8/15 kV only)
		NA11	100 A, 20 kAIC, barrel exp. cap (rated 7.8/15 kV only)
		DA21	200 A, 12 kAIC, solid cap (rated 7.8/15 kV only)
		PA21	200 A, 20 kAIC, barrel exp. cap (rated 7.8/15 kV only)
		BM11	100 A, 10 kAIC, solid cap (rated 15 kV)
		QA11	100 A, 16 kAIC, barrel exp. cap (rated 15 kV only)
		EA21	200 A, 8 kAIC, solid cap (rated 15 kV)
		GA21	200 A, 10 kAIC, link extender (rated 15 kV)
		UA21	200 A, 12 kAIC, barrel exp. cap (rated 15 kV only)
		VA31	300 A, solid blade (rated for 7.8/15 kV and 15 kV)
7-10	Fuseholder	0000	Fuse support only (no tube)

1202 - THREE PHASE EQUIPMENT MOUNTING BRACKET

EACH RISER POLE SHALL BE FURNISHED WITH A THREE PHASE EQUIPMENT MOUNTING BRACKET TO SUPPORT FUSED CUTOUTS AND LIGHTNING ARRESTERS.

MANUFACTURER IS HUBBELL POWER SYSTEMS OR EQUAL CAT # CTBEMB16PA35, COMPONENT CAT# C2PA (2) PER BRACKET.

Home > Products > Pole Line Hardware > Equipment Mounting Brackets > 3 Phase Terminator & Arrester > Terminator & Arrester Brackets

Terminator & Arrester Brackets

Bracket for three phase mounting of terminators and/or arresters. Extruded aluminum material offers lightweight for easy handling. Mounts to pole with 5/8" thru-bolt and 1/2" lag screw. Shipped completely assembled. Mounting hardware is purchased separately.



3 Phase Terminator and Arrester Brackets

Catalog Number	Hole to Hole Distance - A	Extension from Pole	Mounting Hole Spacing	Mounting Hardware (Not Included)	Approx. Ship Wt. per Each
CTBEMB16PA	24"	8-7/8"	3-5/8"	5/8" Through Bolt & 1/2" Lag Screw	8.00 lbs.
CTBEMB16PA35	35"				9.00 lbs.

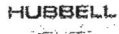

All contents Copyright © 2001 - 2011 Hubbell Incorporated. All rights reserved. Because Hubbell has a policy of continuous product improvement, we reserve the right to change design specifications without notice.
[Terms of Use](#) | [Contact Us](#) | [Site Map](#)

Home > Products > Pole Line Hardware > Equipment Mounting Brackets > 3 Phase Terminator & Arrester > Terminator & Arrester Bracket Components

Terminator & Arrester Bracket Components

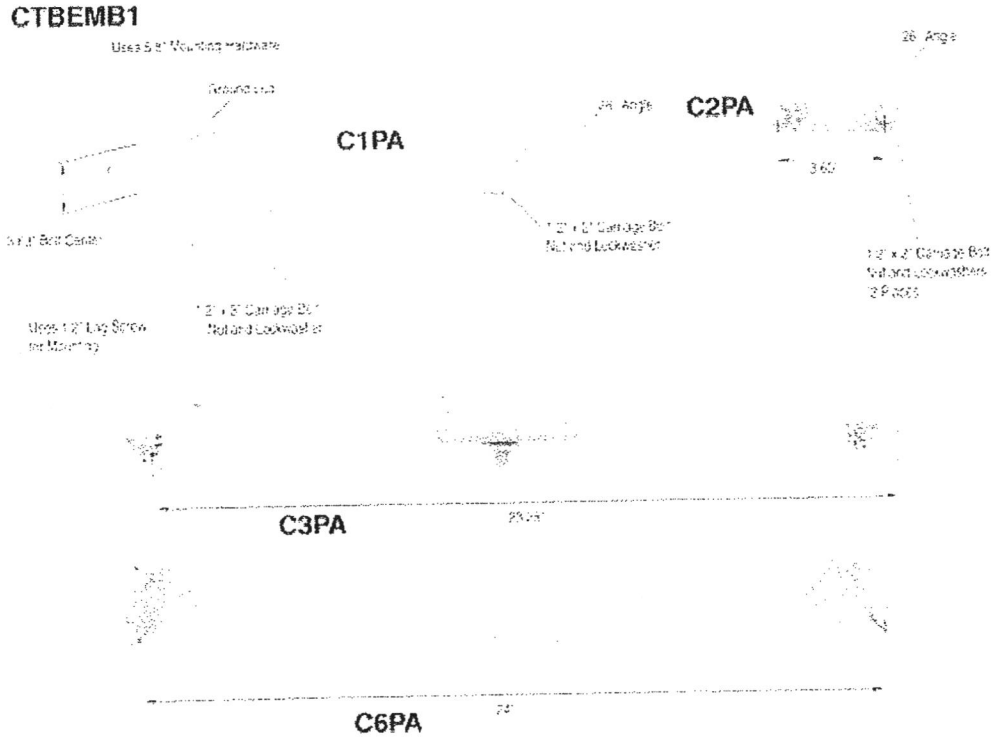

Terminator and Arrester Bracket Components

Catalog Number	Description	Approx. Ship Wt. per Each
CTBEMB1	Pole Mounting Bracket	3.00 lbs.
C1PA	Single Position Bracket	1.00 lbs.
C2PA	Two Position Bracket	1.50 lbs.
C3PA	Three Phase Terminator Bracket	4.00 lbs.
C6PA	Three Phase Terminator & Arrester Bracket	5.00 lbs.

1203 - 9 KV DISTRIBUTION ARRESTER

EACH PRIMARY CABLE SHALL HAVE A 9 KV LIGHTNING ARRESTER ATTACHED AT THE TOP OF THE PRIMARY RISER POLE.

LIGHTNING ARRESTERS SHALL BE DISTRIBUTION CLASS , CROSSARM MOUNT.

LIGHTNING ARRESTERS SHALL BE SO LOCATED THAT EXHAUST OF THE ARRESTER SHALL NOT ENDANGER PERSONNEL OR EQUIPMENT.

THE MINIMUM STANDARD FOR LIGHTNING ARRESTERS SHALL BE MACCLEAN POWER SYSTEMS TYPE ZHP 9KV DISTRIBUTION SURGE ARRESTER, CAT # ZHP009-0C00100 WITH CROSSARM BRACKET AS PRESENTED IN SECTION 1203.1, 1203.2

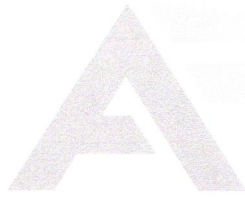

ALUMA-FORM

Best in class design. Complete offering has passed the latest ANSI/IEEE standards and are ***RUS approved.***

Our arrester terminal options include Stainless steel stud, washers, and wire clamps with silicon bronze nut.

The stainless steel protective cap wrap around design protects the top edge of the insulator and provides an area for the arrester's specifications to be engraved.

The aluminum alloy electrode is threaded, glued, and pinned into the tube structure. Benefits are:

- Eliminates extreme pressure spikes during surges.
- Resists rotation from tightening hardware.
- Prevents movement from vibration and temperature cycles.

Seamless tube provides the best choice for arrester housings

- Ultimate structural integrity throughout the arrester housing compared to other methods (wrap / cage)
- Precision dimensional control for tighter tolerance

Proprietary blended silicon rubber fully encapsulates arrester stack.

- Hermetically sealed
- No chance of air/water ingress
- Sheds sized and shaped for optimized insulating properties

Insulator bracket constructed using high strength fiberglass

- UV resistant
- Flame resistant
- Solid body
- Universal design for size interchangeability
- Three sizes available

Ground lead disconnect meets all of the most current IEEE testing requirements

- External mount for easier identification of operation
- No wrench design to alleviate potential damage
- Superior low current performance

Optional wildlife protector allows for isolation of connections

- UV resistant
- Impact resistant
- High Profile for maximum internal volume

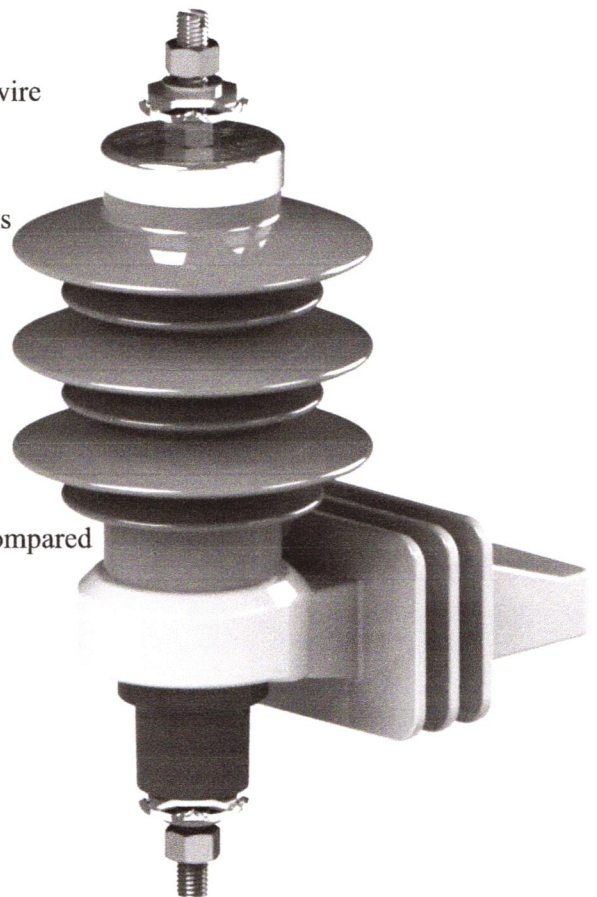

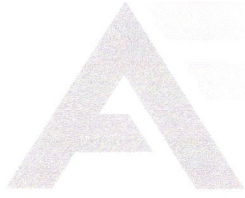

ALUMA-FORM

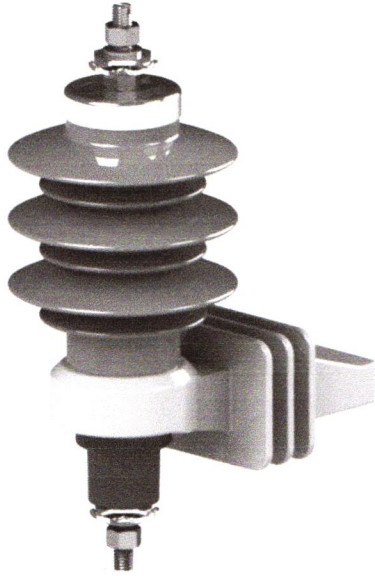

TOV Curve - No Prior Duty

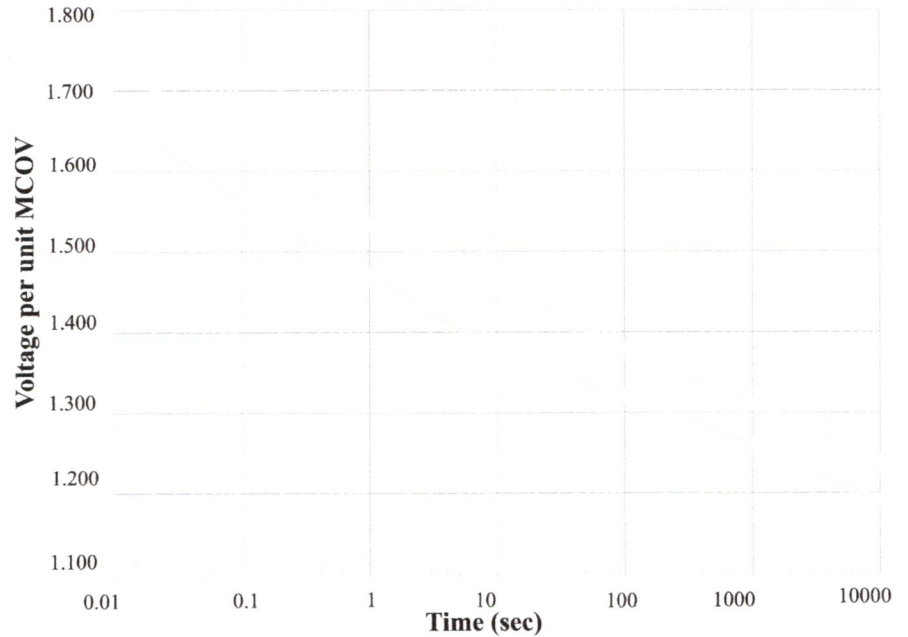

HD
RP

2.55	10.3	7.5	7.8	8.4	8.7	9.4	10.7	12.5
5.1	20.4	14.9	15.6	16.8	17.2	18.6	21.2	24.8
7.65	30.5	22.2	23	24.9	25.7	27.8	31.7	37.2
8.4	33.8	24.1	25.2	27.1	28.3	30.7	34.8	40.8
10.2	40.4	29.2	30.4	32.8	34.1	37	42.2	49.4
12.7	50.5	36.5	38.1	41	42.8	46.2	52.7	61.7
15.3	60.6	43.4	45.3	49.2	51	55.4	63.2	73.9
17	70.7	51.1	53.1	57	59.4	64.5	73.6	86.1
19.5	80.8	58.4	60.8	65.2	67.8	73.6	84	98.4
22	90.9	65.7	68.4	73.4	76.4	82.8	94.6	110.8
24.4	101	74	75.6	80.8	85	94	105.5	124
27	111.1	81.4	85.1	90.4	93.5	103.4	115.5	136.4
29	121.2	88.8	90.7	97.1	102	112.8	126	148.8



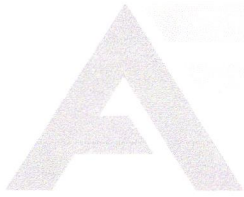

ALUMA-FORM

AHD-10B-1GX-4X1-4X-B

Arrester Type

AHD = Arrester Heavy Duty

ARP = Arrester Riser Pole

*Add a - T for Titan or - D for Directional

kV Rating of Arrester

03 - 3kV	15 - 15kV	
06 - 6kV	18 - 18kV	
09 - 9kV	21 - 21kV	30 - 30kV
10 - 10kV	24 - 24kV	33 - 33kV
12 - 12kV	27 - 27kV	36 - 36kV

Housing Size

A - Hsg A (3kV)	
B - Hsg B (6, 9, 10kV)	
C - Hsg C (12)	
D - Hsg D (15 & 18kV)	
E - Hsg E (21kV)	G - Hsg G (30 & 33kV)
F - Hsg F (24 & 27kV)	H - Hsg H (36kV)

Isolator Bracket Size

- 1 - Size 1 Isolator (3-10kV)
- 2 - Size 2 Isolator (12-15kV)
- 3 - Size 3 Isolator (18-27kV)

Ground Lead Disconnect

- G - with GLD
- X - without GLD

Mounting Bracket options

- | | |
|-------------------------|--------------------------------|
| A - Nema A Crossarm | T - Top Mount Crossarm Bracket |
| B - Nema B Crossarm | X - No Bracket |
| C - Transformer, small | |
| D - Transformer, medium | |
| E - Transformer, large | |

Hardware (Top of Arrester)

- 1 - SS nut, 4-corner, flat wash, lock wash
- 2 - SS nut, two 4-corner, lock wash
- 3 - Si Bronze nut, 4-corner, flat wash, lock wash
- 4 - Si Bronze nut, two 4-corner, lock wash
- 5 - SS nut, lock wash, flat wash
- 6 - Si Bronze nut, lock wash, flat wash
- X - No hardware

Line Lead (Top of Arrester)

- A - 18" #6 Insulated Wire Lead, strip 1.25" both ends
- B - 18" #6 Insulated Wire Lead, strip 1.25"/ ring term
- C - 18" #6 Insulated Wire Lead, 2 ring term
- D - Overhead Primary Tap - #2-556 Al or Cu
- E - 84" #6 Insulated Wire Lead, strip 1.25"/ ring term
- F - 12" #4 Tinned Copper Braided Conductor
- X - No line term. wire

Additional Options

B - Boss Mounting Hardware (only with mounting brackets options C, D, & E)

W- Wildlife Isolator Bracket Cover

Ground Lead (Bottom)

- A - 18" #6 wire lead, strip 1.25" both ends
- B - 18" #6 wire lead, strip 1.25"/ ring term
- C - 18" #6 wire lead, 2 ring term
- D - 12" copper strap
- X - No ground term, wire

Hardware (Bottom)

- 1 - SS nut, 4-corner, flat wash, lock wash
- 2 - SS nut, two 4-corner, flat wash, lock wash
- 3 - Si Bronze nut, 4-corner, flat wash, lock wash
- 4 - Si Bronze nut, two 4-corner, lock wash
- 5 - SS nut, lock wash, flat wash
- 6 - Si Bronze nut, lock wash, flat wash
- X - No hardware

Top (options)

- 1 - Wildlife protection cap
- 2 - Flipper fuse kit
- X - No option